

Heating

Cooling

Fresh Air

Clean Air



All rights reserved.

This manual has been compiled with the most care. The publisher cannot be held liable for any damage caused as a result of missing or incorrect information in this manual. In case of disputes the Dutch version of these instructions will be binding.

Table of Contents

TABLE OF CONTENTS	III
Preface.....	1
1 INTRODUCTION.....	1
1.1 Warranty and liability	1
1.1.1 Warranty conditions	1
1.1.2 Liability	1
1.2 Safety.....	2
1.2.1 Safety regulations	2
1.2.2 Safety provisions and measures	2
1.2.3 Pictograms used	2
2 FOR THE INSTALLER	3
2.1 ComfoAir configuration	3
2.2 Technical specifications	4
2.3 Dimension sketch.....	6
2.4 Installation conditions.....	7
2.5 Installation of the ComfoAir.....	7
2.5.1 Transport and unpacking.....	7
2.5.2 Checking the delivery.....	7
2.6 Mounting of the ComfoAir	7
2.6.1 Mounting on the wall.....	7
2.6.2 Connection of the air ducts	7
2.6.3 Connection of the condensation drain	8
2.7 Commissioning the ComfoAir.....	9
2.7.1 P menus for the user	10
2.7.2 P menus for the installer	11
2.8 Programming air specifications.....	15
2.9 Maintenance by the installer.....	16
2.9.1 Inspecting and cleaning the heat exchanger.....	16
2.9.2 Inspecting and cleaning the fans	17
2.10 Malfunctions	17
2.10.1 Malfunction alerts on the digital operating device	17
2.10.2 What to do in the event of a malfunction / Trouble shooting	18
2.10.3 Malfunctions (or problems) without alerts.....	26
2.11 Service parts.....	27
2.12 Wiring diagram: ComfoAir 550 Luxe – LEFT-HAND version.....	28
2.13 Wiring diagram: ComfoAir 550 Luxe – RIGHT-HAND version	29
2.14 UL Listing Declaration.....	30
2.15 Temperature conversion table	30



Carefully read this manual before use.

This manual provides all the information required for safe and optimal installation and maintenance of the ComfoAir 550 Luxe. It is also intended as a reference for servicing, so that this can be carried out in a responsible manner. The device is subject to continuous development and improvement. As a result, the ComfoAir 550 Luxe may slightly differ from the descriptions.

NOTE

This manual has been compiled with the most care. However, no rights can be derived from it. In addition, we at all times reserve the right to change the contents of this manual, without prior notice.

1 Introduction

The device's name is ComfoAir 550 Luxe. In the following it will be referred to as ComfoAir.

The ComfoAir is a balanced ventilation system with heat recovery in order to create healthy, balanced and energy-efficient ventilation in houses. The ComfoAir has a UL marking on the identification plate. The identification plate can be found on top of the ComfoAir.

1.1 Warranty and liability

1.1.1 Warranty conditions

The ComfoAir is covered by a manufacturer's warranty for a period of 24 months after fitting up to a maximum of 30 months after the date of manufacture. Warranty claims may only be submitted for material faults and/or construction faults arising during the warranty period. In the case of a warranty claim, the ComfoAir must not be dismantled without written permission from the manufacturer. Spare parts are only covered by guarantee, if they were supplied by the manufacturer and have been installed by an approved installer.

The warranty becomes invalid if:

- The warranty period has elapsed;
- The device is used without filters;
- Parts are used that have not been supplied by the manufacturer;
- Non-authorized changes or modifications have been made to the unit.

1.1.2 Liability

The ComfoAir has been designed and manufactured for use in "balanced ventilation systems". Any other use is deemed unintended use and can lead to damage to the ComfoAir or personal injury, for which the manufacturer cannot be held liable.

The manufacturer is not liable for any damage originating from:

- Non-compliance with the safety, operating and maintenance instructions in this manual;
- The use of components not supplied or recommended by the manufacturer.
Responsibility for the use of such components lies entirely with the installer;
- Normal wear and tear.

1.2 Safety

1.2.1 Safety regulations

Always comply with safety regulations in this manual. Non-compliance with the safety regulations, warnings, notes and instructions in this manual can cause personal injury or damage to the ComfoAir.

- The ComfoAir may only be installed, connected, rendered operational and maintained by an appropriately approved installer, unless otherwise indicated in this manual;
- Installation of the ComfoAir must be carried out in accordance with the general and locally applicable construction, safety and installation instructions of the local council, electricity and water boards or other agencies;
- Observe the safety regulations, warnings, comments and instructions as prescribed in this manual at all times;
- Keep this manual with the ComfoAir throughout its life;
- Instructions with regard to cleaning or replacing the filters of the intake and exhaust valves must be carefully observed;
- The specifications stated in this document may not be changed;
- Modifying the ComfoAir is not allowed;
- Always take ESD-inhibiting measures when dealing with electronics, such as wearing an antistatic wristband. The electronics can be damaged by static charges;
- The ComfoAir is only suitable for connection to 230V 50Hz or 240V 60Hz mains. Use 15A circuit breaker or fuse in supply circuit. Class 3 wiring is required to be used, in accordance with Article 725 of the National Electrical Code, if the wiring extends into areas where wet contact is likely;
- For residential installation only;
- Do not install in a cooking area or connect directly to any appliance. Recommended maximum ambient temperature is 122°F (50°C);
- It is recommended to take out a maintenance contract so that the device is checked on a regular basis.

1.2.2 Safety provisions and measures

- The ComfoAir cannot be opened without using tools;
- It should not be possible to touch the fans, therefore ducting must be connected to the ComfoAir at a minimum duct length of 35 inch (900mm).

1.2.3 Pictograms used

The following pictograms are used in this manual:



Point of attention.



Risk of:

- **damage to the device;**
- **performance of the device is compromised if instructions are not observed carefully.**



Risk of personal injury to the user or installer.

The ComfoAir identification plate is shown below:

 LISTED Ducted Heat Recovery Ventilator Control nr.4SV9 UL file E345822 Zehnder Group Nederland B.V.	  Fan Motors: THERMALLY PROTECTED PROTECTION THERMIQUE INHÉRENTE Fan motor: 200-277 Vac, 50/60 Hz, 1.3A Manufactured at Zehnder Group, The Netherlands.
ComfoAir 550 USA L Luxe ERV 230/ 240V 50/60Hz 1~ 2.46 A 0.35 kW Iso.Cl. B IP44	471336435 132210001
	
(91)471336435(10)132210001(99)1	
<ul style="list-style-type: none">● A BRANCHE-CIRCUIT PROTECTIVE DEVICE HAS TO BE INSTALLED OF 15A FOR THIS DEVICE CONNECTER L'APPAREIL A UN CIRCUIT PROTÉGÉ PAR UN FUSIBLE DE 15A● DO NOT INSTALL IN A COOKING AREA OR CONNECT DIRECTLY TO ANY APPLIANCE NE PAS INSTALLER DANS UNE AIRE DE CUISSON NI RACCORDER DIRECTEMENT A UN APPAREIL● FOR RESIDENTIAL INSTALLATION ONLY POUR INSTALLATION RÉSIDENNELLE INTÉRIEURE SEULEMENT● FOR USE WITH LOW VOLTAGE SPEED CONTROLLER MODEL POUR USAGE AVEC UN RÉGULATEUR DE VITESSE À BASSE TENSION	

2 For the Installer

2.1 ComfoAir configuration

The standard ComfoAir configuration consists of:

- External casing (A) of coated sheeting;
- Interior (B) of high-quality, expanded polypropylene (E)PP;
- 4 connections (C) for the air ducts;
- 2 plate filters (D) for air purification. Filter classification: outside air G4, return air G4;
- 2 energy-efficient DC motors (E) with high-efficient fan;
- HE (High Efficient) heat exchanger (with optional moisture exchanger) (F);
- Display (G) to read data and for setting procedures;
- Electronics compartment (H) for connecting external switches and controllers;
- Removable PCB unit (H₂);
- Identification plate (I) detailing information on the ComfoAir (not visible);
- Condensation drain connector (J);
- Sticker (K) detailing air connections;
- Cable for power supply with 240V ground connection plug (L).

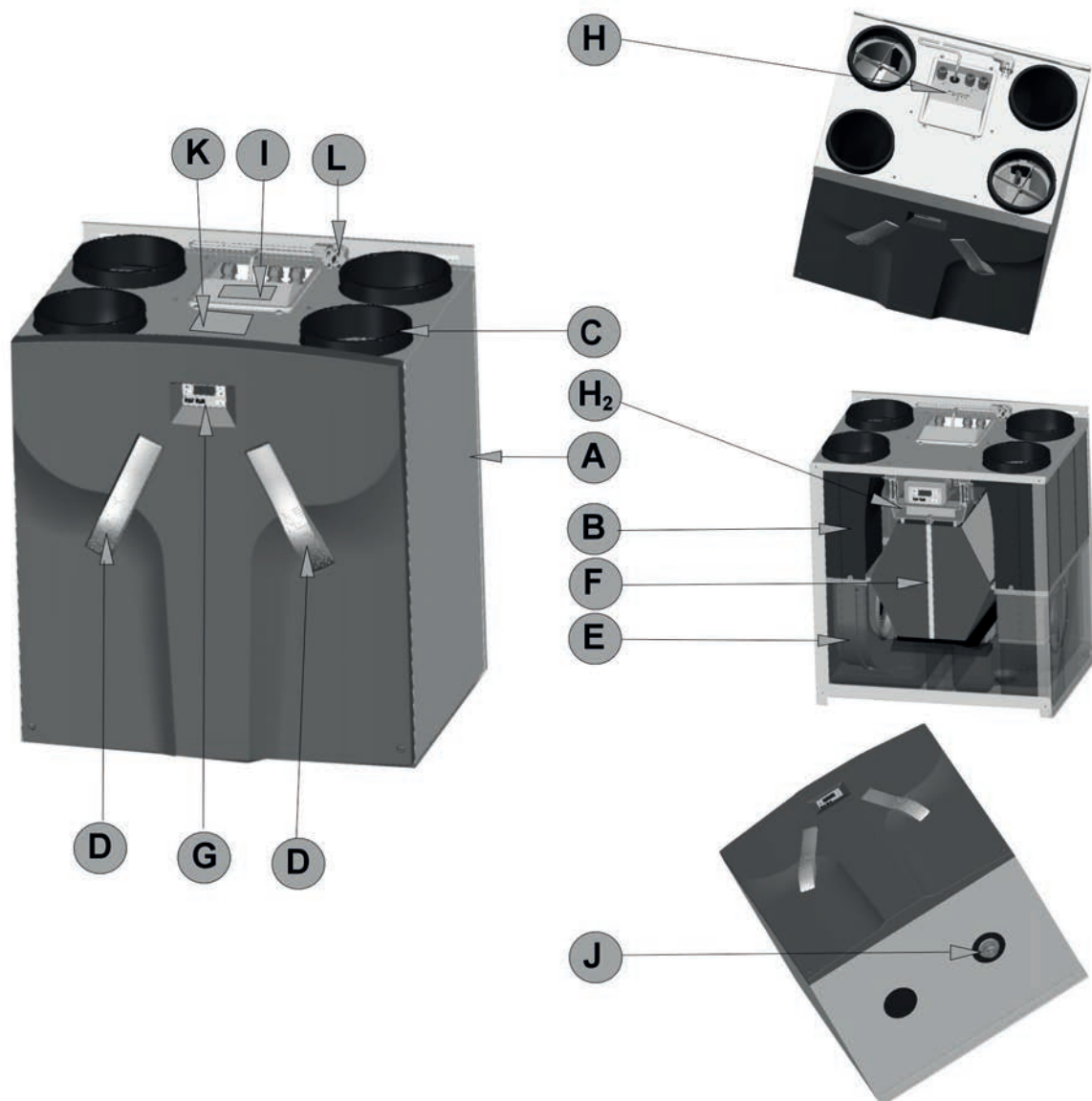

2.2 Technical specifications

ComfoAir 550 Luxe (nL setting)		
Position	Ventilation capacity	Power
Absent Setting	29.43 CFM (50 m ³ /h) at 0.02 in.w.c. (5 Pa)	13 W
Low Setting	88.29 CFM (150 m ³ /h) at 0.20 in.w.c. (50 Pa)	30 W
Medium Setting	132.43 CFM (225 m ³ /h) at 0.40 in.w.c. (100 Pa)	69 W
High Setting	194.23 CFM (330 m ³ /h) at 0.86 in.w.c. (215 Pa)	160 W
Maximum	270.75 CFM (460 m ³ /h) at 1.65 in.w.c. (410 Pa)	350 W
Position	Ventilation capacity	Current
Absent Setting	29.43 CFM (50 m ³ /h) at 0.02 in.w.c. (5 Pa)	0.12 A
Low Setting	88.29 CFM (150 m ³ /h) at 0.20 in.w.c. (50 Pa)	0.25 A
Medium Setting	132.43 CFM (225 m ³ /h) at 0.40 in.w.c. (100 Pa)	0.57 A
High Setting	194.23 CFM (330 m ³ /h) at 0.86 in.w.c. (215 Pa)	1.21 A
Maximum	270.75 CFM (460 m ³ /h) at 1.65 in.w.c. (410 Pa)	2.46 A

Electricity		
Power supply		230 / 50-60 V/Hz
Cos.phi at Maximum		0.8
Connecting Power		1.70 kW
Maximum Power Pre-heater		1.35 kW
Leakage current		<1mA

Supply fan noise level (at 0 m)		
Position	Ventilation capacity	Sound power
Absent Setting	29.43 CFM (50 m ³ /h) at 0.02 in.w.c. (5 Pa)	36 dB(A)
Low Setting	88.29 CFM (150 m ³ /h) at 0.20 in.w.c. (50 Pa)	54 dB(A)
Medium Setting	132.43 CFM (225 m ³ /h) at 0.40 in.w.c. (100 Pa)	63 dB(A)
High Setting	194.23 CFM (330 m ³ /h) at 0.86 in.w.c. (215 Pa)	71 dB(A)
Maximum	270.75 CFM (460 m ³ /h) at 1.65 in.w.c. (410 Pa)	79 dB(A)

Exhaust fan noise level (at 0 m)		
Position	Ventilation capacity	Sound power
Absent Setting	29.43 CFM (50 m ³ /h) at 0.02 in.w.c. (5 Pa)	29 dB(A)
Low Setting	88.29 CFM (150 m ³ /h) at 0.20 in.w.c. (50 Pa)	39 dB(A)
Medium Setting	132.43 CFM (225 m ³ /h) at 0.40 in.w.c. (100 Pa)	49 dB(A)
High Setting	194.23 CFM (330 m ³ /h) at 0.86 in.w.c. (215 Pa)	63 dB(A)
Maximum	270.75 CFM (460 m ³ /h) at 1.65 in.w.c. (410 Pa)	63 dB(A)

ComfoAir 550 Luxe (HL setting)		
Position	Ventilation capacity	Power
Absent Setting	29.43 CFM (50 m ³ /h) at 0.02 in.w.c. (5 Pa)	13 W
Low Setting	105.94 CFM (180 m ³ /h) at 0.24 in.w.c. (60 Pa)	41 W
Medium Setting	194.23 CFM (330 m ³ /h) at 0.86 in.w.c. (215 Pa)	160 W
High Setting	253.09 CFM (430 m ³ /h) at 1.45 in.w.c. (360 Pa)	310 W
Maximum	270.75 CFM (460 m ³ /h) at 1.65 in.w.c. (410 Pa)	350 W
Position	Ventilation capacity	Current
Absent Setting	29.43 CFM (50 m ³ /h) at 0.02 in.w.c. (5 Pa)	0.12 A
Low Setting	105.94 CFM (180 m ³ /h) at 0.24 in.w.c. (60 Pa)	0.35 A
Medium Setting	194.23 CFM (330 m ³ /h) at 0.86 in.w.c. (215 Pa)	1.21 A
High Setting	253.09 CFM (430 m ³ /h) at 1.45 in.w.c. (360 Pa)	2.22 A
Maximum	270.75 CFM (460 m ³ /h) at 1.65 in.w.c. (410 Pa)	2.46 A

Electricity		
Power supply		230 / 50-60 V/Hz
Cos.phi at Maximum		0.8
Connecting Power		1.70 kW
Maximum Power Pre-heater		1.35 kW
Leakage current		<1mA

Supply fan noise level (at 0 m)		
Position	Ventilation capacity	Sound power
Absent Setting	29.43 CFM (50 m ³ /h) at 0.02 in.w.c. (5 Pa)	36 dB(A)
Low Setting	105.94 CFM (180 m ³ /h) at 0.24 in.w.c. (60 Pa)	58 dB(A)
Medium Setting	194.23 CFM (330 m ³ /h) at 0.86 in.w.c. (215 Pa)	71 dB(A)
High Setting	253.09 CFM (430 m ³ /h) at 1.45 in.w.c. (360 Pa)	78 dB(A)
Maximum	270.75 CFM (460 m ³ /h) at 1.65 in.w.c. (410 Pa)	79 dB(A)

Exhaust fan noise level (at 0 m)		
Position	Ventilation capacity	Sound power
Absent Setting	29.43 CFM (50 m ³ /h) at 0.02 in.w.c. (5 Pa)	29 dB(A)
Low Setting	105.94 CFM (180 m ³ /h) at 0.24 in.w.c. (60 Pa)	44 dB(A)
Medium Setting	194.23 CFM (330 m ³ /h) at 0.86 in.w.c. (215 Pa)	55 dB(A)
High Setting	253.09 CFM (430 m ³ /h) at 1.45 in.w.c. (360 Pa)	63 dB(A)
Maximum	270.75 CFM (460 m ³ /h) at 1.65 in.w.c. (410 Pa)	63 dB(A)

General Specifications		
HE Exchanger Material		Polystyrene
Interior Material		(E)PP / PA / PA
Thermal Yield		95%
Mass		103.62 lb (47 kg)
Maximum ambient temperature		122°F

2.3 Dimension sketch

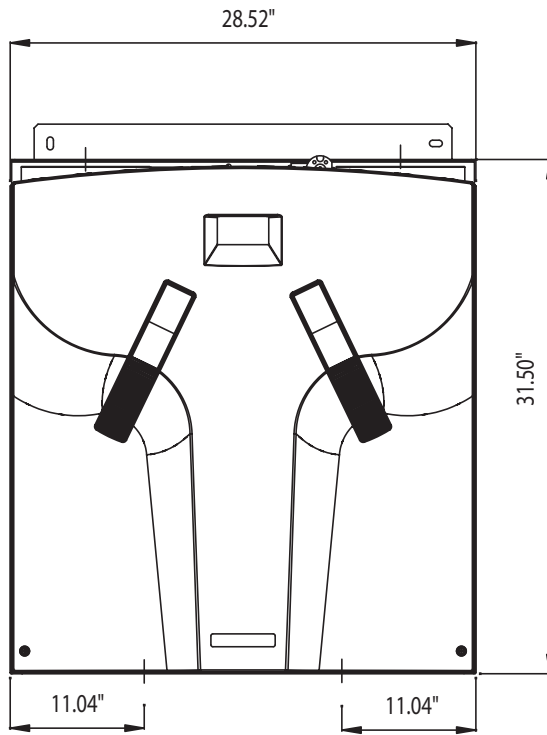
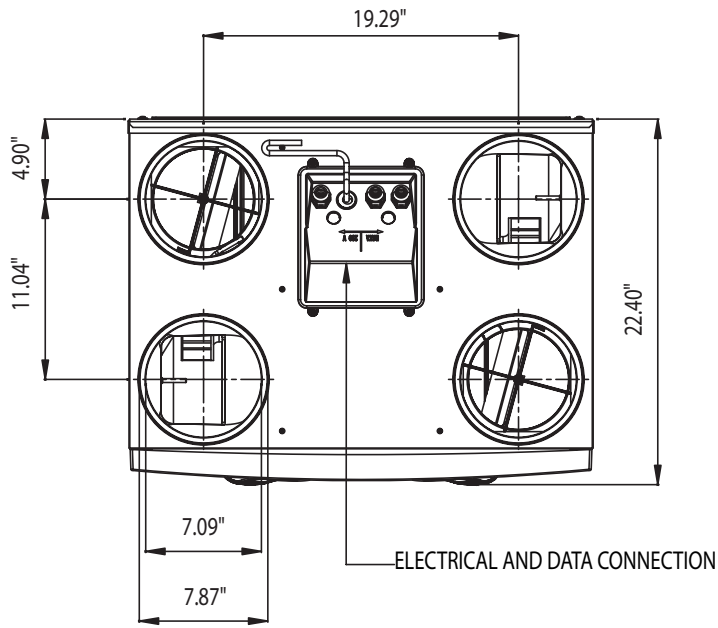

CONDENSATION DRAIN
RIGHT-HAND VERSION

CONDENSATION DRAIN
LEFT-HAND VERSION

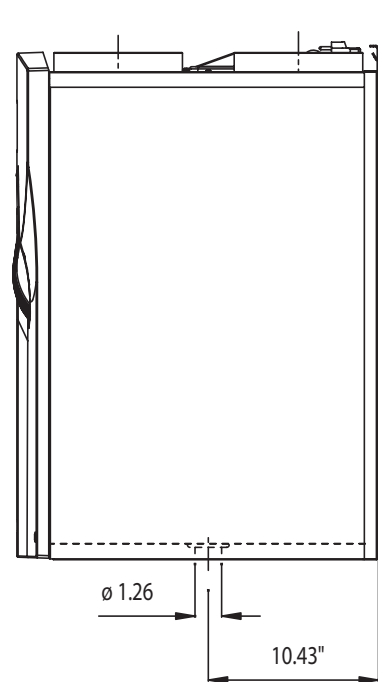

2.4 Installation conditions

In order to determine whether the ComfoAir can be installed in a certain area, the following aspects must be taken into account:

- The ComfoAir must be installed according to the general and locally applicable safety and installation regulations of power and water companies, as well as the instructions in this manual.
- The system must be fitted to allow sufficient room around the ComfoAir for the air connections and supply and exhaust ducts as well as for carrying out maintenance activities.
- The ComfoAir must be installed in a frost-free space. The condensation must be drained off frost-free, at a gradient and incorporate a 'U' bend.
- We do not recommend installing the ComfoAir in areas with a higher average humidity (such as bathroom or toilet). This will prevent condensation on the outside of the ComfoAir.
- The room must offer the following provisions:
 - Air duct connections.
 - 230V electrical connection.
 - Provisions for the condensation drain.
 - Wiring for an wired switch.
- A gap should be left near the doors in order to ensure effective and draughtfree airflow in the house. A gap under the inside doors must be at least 0.39 inch (10 mm).

⚠ If these openings are obstructed, due to draught blockers or deep-pile carpet, the airflow in the house will stagnate. As a result, system performance will be compromised or fail altogether.

2.5 Installation of the ComfoAir

2.5.1 Transport and unpacking

Take the necessary precautions when transporting and unpacking the ComfoAir.

👉 Make sure the packing material is disposed in an environmentally friendly manner.

2.5.2 Checking the delivery

Contact your supplier immediately in case of damage or an incomplete delivery. The delivery must include:

- ComfoAir;
Check the identification plate to ensure that it is the required type.
- Mounting bracket;
- Documentation.

The ComfoAir is supplied in the following types:

Type
ComfoAir 550 L Luxe ERV
ComfoAir 550 R Luxe ERV

Meaning of the suffixes:

- * L = Left version
- * R = Right version
- * ERV = Contains an enthalpy exchanger by default.
- * Luxe = Contains a connection board with extra function by default.

ComfoSense panel can be ordered separately.

2.6 Mounting of the ComfoAir

2.6.1 Mounting on the wall

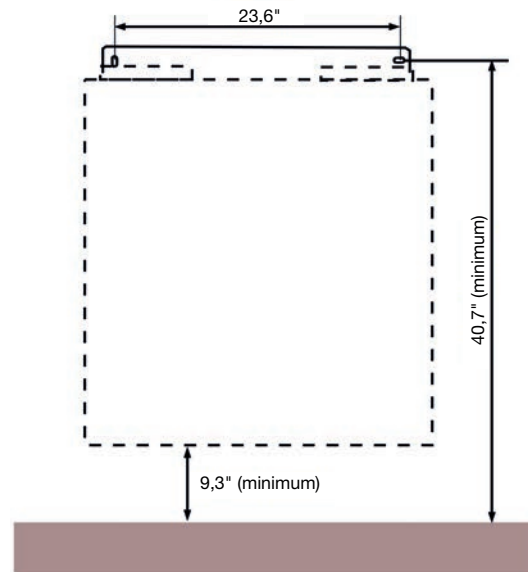

Mount the ComfoAir against a wall with a minimum mass of 0.28 lb/in² (200 kg/m²). For other types of wall, we recommend using the Zehnder mounting frame on the floor (available as an optional extra). This reduces contact noise as much as possible. The ComfoAir does not require any space at the sides for effective operation.

👉 Do not mount the side of the ComfoAir against the wall due to the risk of impact sound.

1. Fasten the mounting bracket to the wall. Make sure it is level and at least 40.7 inch (1035 mm) from the floor (depending on the type of condensation drain selected).

⚠ Leave a minimum space of 3.3 feet (1m) in front of the ComfoAir for carrying out maintenance.

2. Hang the ComfoAir on the mounting bracket.
3. Mount the condensation drain under the ComfoAir. The stated dimension of 9.3 inch (235 mm) is an indication only, and is dependent on the type of condensation drain selected.

2.6.2 Connection of the air ducts

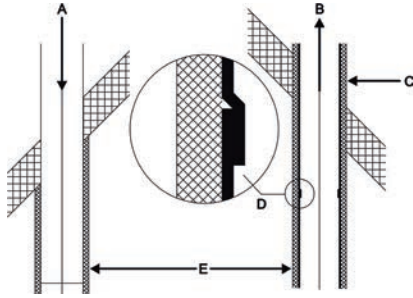

The following aspects must be taken into account, while installing the air ducts:

- Install the air exhaust duct so it drains in the direction of the ComfoAir.
- Insulate the outside air supply and the air exhaust duct between the roof/wall passage to render the ComfoAir damp proof. This prevents the formation of condensation on the outside of the ducts.
- To prevent unnecessary temperature loss in either the summer or the winter, we recommend fitting thermal and damp-proof insulation to the supply ducts from the ComfoAir up to the supply valves.
- Install the air ducts with a minimum \varnothing of 7.09 inch (180 mm), as little air resistance as possible and free from air leakage.
- Install a silencer of at least 3.3 feet (1m) straight directly onto the supply and return airconnections. For relevant advice, please contact Zehnder.
- Do not install a flexible air duct system. These will disturb the basic operating principle of the balanced ventilation system.
- We recommend that the ventilation system is fitted with intake and exhaust valves made by Zehnder.

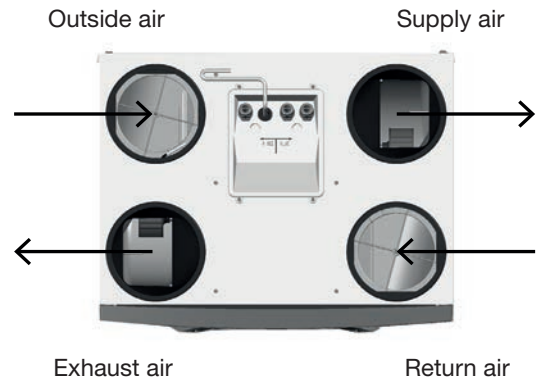

ComfoAir - Right

2.6.3 Connection of the condensation drain

The ComfoAir is fitted with an enthalpy exchanger the humidity from the extracted air is partly transferred to the fresh supply air. In this case you delay the process of drying out the house in dry winter months, additionally there is no condensate that must be drained from the ComfoAir. Therefore a condensation drain is not necessary with an enthalpy exchanger.

⚠ Ensure that the condensation drain is sealed. This prevents the ComfoAir from sucking in any leakage air.

The condensation drain can be sealed with a standard screw-cap.

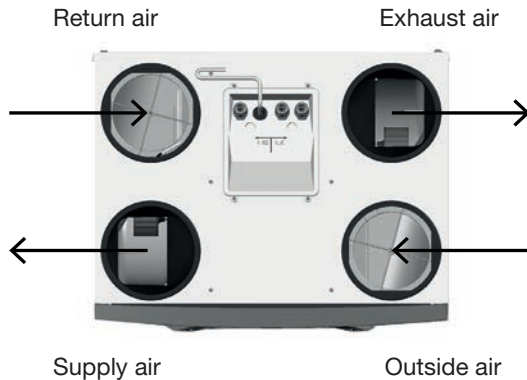

ComfoAir - Left

2.7 Commissioning the ComfoAir

After installation, the ComfoAir must be commissioned.

This can be done via the P menus on the digital operating device. These P menus can be used to enter various settings (ventilation programmes, in particular) for the ComfoAir. An overview of the available P menus is given below:

Menu	Options
P1	Reading statuses (from menu P2)
P2	Setting time delays
P3	Setting and reading the ventilation levels
P4	Setting and reading the temperatures
P5	Setting additional programmes
P6	Setting additional programmes
P7	Reading and resetting malfunctions (and system information)
P8	Setting the RF input and analogue inputs (0-10V)
P9	Reading statuses (from menu P5 and P6)

P menus P1, P2 and P9 can be accessed by the user, mainly to read statuses and set time delays. The remaining P menus P3 to P8 are intended **solely** for the installer.

 **The ComfoAir's bypass valve will not work for the first 4 minutes after a power cut unless the programme mode is activated.**

Menu P1 → Status of programmes

Sub-menu	Description	Status
		Activated
P10	Is menu 20 currently active?	Yes (1) / No (0)
P11	Is menu 21 currently active?	Yes (1) / No (0)
P12	Is menu 22 currently active?	Yes (1) / No (0)
P13	Is menu 23 currently active?	Yes (1) / No (0)
P14	Is menu 24 currently active?	Yes (1) / No (0)
P15	Is menu 25 currently active?	Yes (1) / No (0)
P16	Is menu 26 currently active?	Yes (1) / No (0)
P17	Is the Summermode currently active?	Yes (1) / No (0)
P19	Is menu 29 currently active?	Yes (1) / No (0)

Menu P2 → Setting time delays

Sub-menu	Description	Time delay values		
		Minimum	Maximum	General Reset
P20	n/a	0 Min.	180 Min.	0 Min.
P21 (Optional)	Delay timer for the bathroom switch (to switch to high position). ■ 'x' minutes after operating the bathroom switch, the ComfoAir switches to the high setting. - Low voltage input	0 Min.	15 Min.	0 Min.
Note: Only applies to systems fitted with a corded switch and a second switch in the bathroom.				
P22 (Optional)	Overrun timer for the bathroom switch (to switch to normal position). ■ 'x' minutes after operating the bathroom switch, the ComfoAir switches back to the normal setting. - Low voltage input	0 Min.	120 Min.	30 Min.
Note: Only applies to systems fitted with a corded switch and a second switch in the bathroom.				
P23	n/a	0 Min.	120 Min.	0 Min.
P24	Filter warning ■ 'x' weeks after cleaning the filters the "filter dirty" alert will reappear.	10 weeks	26 weeks	16 weeks
P25	n/a	1 Min.	20 Min.	10 Min.
P26	n/a	1 Min.	120 Min.	30 Min.
P27	Time for the Boost setting. ■ After turning on the PARTY TIMER on the ComfoSense panel, the ComfoAir will switch to the high setting for 'x' minutes and then automatically returns to the NORMAL setting If any 3-position switch is operated during this lagging time the ComfoAir will instantly revert to the ventilation position as set at that time.	0 Min.	120 Min.	30 Min.
Note: Only applies to systems fitted with a ComfoSense panel.				
P29	n/a	1%	99%	10%

Menu P9 → Status of programmes (from menu P5 and P6 additional programmes)

Sub-menu	Description	Status
		Activated
P90	Open fire programme active?	Yes (1) / No (0)
P91	Bypass Open?	Yes (1) / No (0)
P92	n/a	Yes (1) / No (0)
P93	Afterheater on?	Yes (1) / No (0)
P94	Analogue input (0-10V) active?	Yes (1) / No (0)
P95	Frost protection active?	Yes (1) / No (0)
P96	n/a	Yes (1) / No (0)
P97	Enthalpy programme active?	Yes (1) / No (0)



Menus with a line at minimum and maximum value are Reading menus.

Menu P3 → Setting ventilation programmes

Submenu	Description	Ventilation programme values		
		Minimum	Maximum	General Reset
P30	Setting the capacity (in %) of the exhaust fan in ABSENT POSITION.	0% or 15%	97%	nL / HL 15% / 15%
P31	Setting the capacity (in %) of the exhaust fan in LOW POSITION.	16%	98%	nL / HL 35% / 40%
P32	Setting the capacity (in %) of the exhaust fan in MEDIUM POSITION.	17%	99%	nL / HL 50% / 70%
P33	Setting the capacity (in %) of the exhaust fan to HIGH POSITION.	18%	100%	nL / HL 70% / 90%
P34	Setting the capacity (in %) of the supply fan to ABSENT POSITION.	0% or 15%	97%	nL / HL 15% / 15%
P35	Setting the capacity (in %) of the supply fan in LOW POSITION.	16%	98%	nL / HL 35% / 40%
P36	Setting the capacity (in %) of the supply fan in MEDIUM POSITION.	17%	99%	nL / HL 50% / 70%
P37	Setting the capacity (in %) of the supply fan in HIGH POSITION.	18%	100%	nL / HL 70% / 90%
P38	Current capacity (in %) of the exhaust fan.	-	-	Current %
P39	Current capacity (in %) of the supply fan.	-	-	Current %









Menu P4 → Reading the temperatures

Submenu	Description	Temperature values		
		Minimum	Maximum	General Reset
P40	Current value of Tah (= afterheater temperature)	-	-	Current °C
P41	Comfort temperature	12 °C	28 °C	20 °C
P44	n/a	-	-	Current °C
P45	Current value of T1 (= outside air temperature)	-	-	Current °C
P46	Current value of T2 (= supply air temperature)	-	-	Current °C
P47	Current value of T3 (= return air temperature)	-	-	Current °C
P48	Current value of T4 (= exhaust air temperature)	-	-	Current °C
P49	Current value T _{GE} (= outside air temperature for the geothermal heat exchanger)	-	-	Current °C



All temperatures are in degrees Celsius (°C). In the back of this document you can find an conversion table. ($^{\circ}\text{F} = ^{\circ}\text{C} \times 1.8 + 32$)

Menu P5 → Setting additional programmes

Submenu	Description	Additional programme values		
		Minimum	Maximum	General Reset
P50	Activation of the open fire programme.	0 (= No)	1 (= Yes)	0
P51	n/a	0 (= No)	1 (= Yes)	0
	 Leave the value at '0'.			
P52	n/a	0	3	0
P53	n/a	0 (= No)	1 (= Yes)	0
	 Leave the value at '0'.			
P54	Confirming the presence of a bypass.	0 (= No)	1 (= Yes)	1
	 The standard ComfoAir configuration includes a bypass. Therefore, leave the value at '1'.			
P55	Confirming the presence of a Afterheater. ■ 0; Afterheater not fitted ■ 1; Afterheater fitted ■ 2; Afterheater is fitted and is regulated by a Pulse Width Modulation (PWM) signal.	0 (= No)	2 (= PWM)	0
P56	Setting the required air volume in the house. ■ nL: "normal air volume". ■ HL: "high air volume".	nL	HL	HL
	 Setting the air volume is the starting point for programming the air specifications and setting the fans.			
P57	Setting the ComfoAir type. ■ Li = "Left-hand version". ■ Re = "Right-hand version".	Li	Re	Li
	 With delivery the ComfoAir is correctly pre-programmed at the factory.  After an general reset the pre-programming is lost and the setting must be reset. The right setting is mentioned on the identification plate on top of the ComfoAir.			
P58	n/a	0	1	0
P59	Confirming the presence of an enthalpy exchanger. ■ 0; Enthalpy exchanger not fitted ■ 1; Enthalpy exchanger with RH sensor. ■ 2; Enthalpy exchanger without RH sensor.	0 (= No)	2 (= Yes)	0
	 Ensure the condensation drain is sealed.  If an enthalpy exchanger without a sensor is selected, then the safety programme will not be activated and malfunction alerts EA1 & EA2 will never occur.			



Menu P6 → Setting additional programmes

Submenu	Description	Additional programme values		
		Minimum	Maximum	General Reset
P60	n/a	0 (= No)	3 (= Yes)	0
P61	n/a	0%	99%	0%
P62	n/a	0 oC	15 oC	7 oC
P63	n/a	10 oC	25 oC	23 oC
P64	Tah (Temperature sensor afterheater), desired	5 oC	40 oC	18 oC

 The afterheater will switch off when the desired temperature is reached

Menu P7 → Reading malfunctions (and system information)

 All temperatures are in degrees Celsius (°C). In the back of this document you can find an conversion table. (°F = °C × 1.8 + 32)

Submenu	Description	(Malfunction) information values		
		Minimum	Maximum	General Reset
P70	Current software version.	Version number of the software (without "v")		
P71	Most recent malfunction.	Code in accordance with alarm and malfunction alert		
P72	Malfunction before the most recent one	Code in accordance with alarm and malfunction alert		
P73	Malfunction before the most recent two	Code in accordance with alarm and malfunction alert		
P74	Resetting malfunction(s) ■ Set value to '1' and press "OK" on the ComfoSense panel.	0	1 (= activate)	0
P75	General reset. ■ Set value to '1' and press "OK" on the ComfoSense panel to carry out a general reset. All original software settings are restored following a general reset.	0	1 (= activate)	0
Note:				
 After a general reset, the ComfoAir will ask you to reset the "nL / HL" (see P56) and "Li / Re" (see P57) settings.				
 Following a general reset, all settings and programmes need to be checked and set to the right value.				
P76	Self-testing the ComfoAir	0	1 (= activate)	0
 ■ The ComfoAir will run at maximum Rotation Per Minute (RPM). ■ The bypass valve will open and close.				
P77	Resetting filter dirty counter	0	1 (= activate)	0
Note: This resets the counter that triggers a dirty filter alert on the ComfoAir. This allows the filter to be cleaned or replaced before the dirty filter alert appears.				

Menu P8 → Setting the RF input and digital inputs (0-10V)

Submenu	Description	Analogue input values		
		Minimum	Maximum	General Reset
810	Analogue input 1 0= not fitted 1= fitted	0	1	0
811	0= controlling 1= programming (analogue input 1)	0	1	0
812	set point analogue input 1 (programming)	0	100	50
813	min. setting analogue input 1	0	99	0
814	max. setting analogue input 1	0	100	100
815	0=positive analogue input 1 1=negative setting analogue input 1	0	1	0
816	read-out analogue input 1	0	100	-
820	Analogue input 2 0= not fitted 1= fitted	0	1	0
821	0= controlling 1= programming (analogue input 2)	0	1	0
822	set point analogue input 2 (programming)	0	100	50
823	min. setting analogue input 2	0	99	0
824	max. setting analogue input 2	0	100	100
825	0=positive analogue input 2 1=negative setting analogue input 2	0	1	0
826	read-out analogue input 2	0	100	-
830	Analogue input 3 0= not fitted 1= fitted	0	1	0
831	0= controlling 1= programming (analogue input 3)	0	1	0
832	set point analogue input 3 (programming)	0	100	50
833	min. setting analogue input 3	0	99	0
834	max. setting analogue input 3	0	100	100
835	0=positive analogue input 3 1=negative setting analogue input 3	0	1	0
836	read-out analogue input 3	0	100	-
840	Analogue input 4 0= not fitted 1= fitted	0	1	0
841	0= controlling 1= programming (analogue input 4)	0	1	0
842	set point analogue input 4 (programming)	0	100	50
843	min. setting analogue input 4	0	99	0
844	max. setting analogue input 4	0	100	100
845	0=positive analogue input 4 1=negative setting analogue input 4	0	1	0
846	read-out analogue input 4	0	100	-
850	n/a	0	1	0
851	n/a	0	1	0
852	n/a	0	100	50
853	n/a	0	99	0
854	n/a	0	100	100
855	n/a	0	1	0
856	n/a	0	100	-

2.8 Programming air specifications

After installation, the ComfoAir must be programmed.

inch w.c.

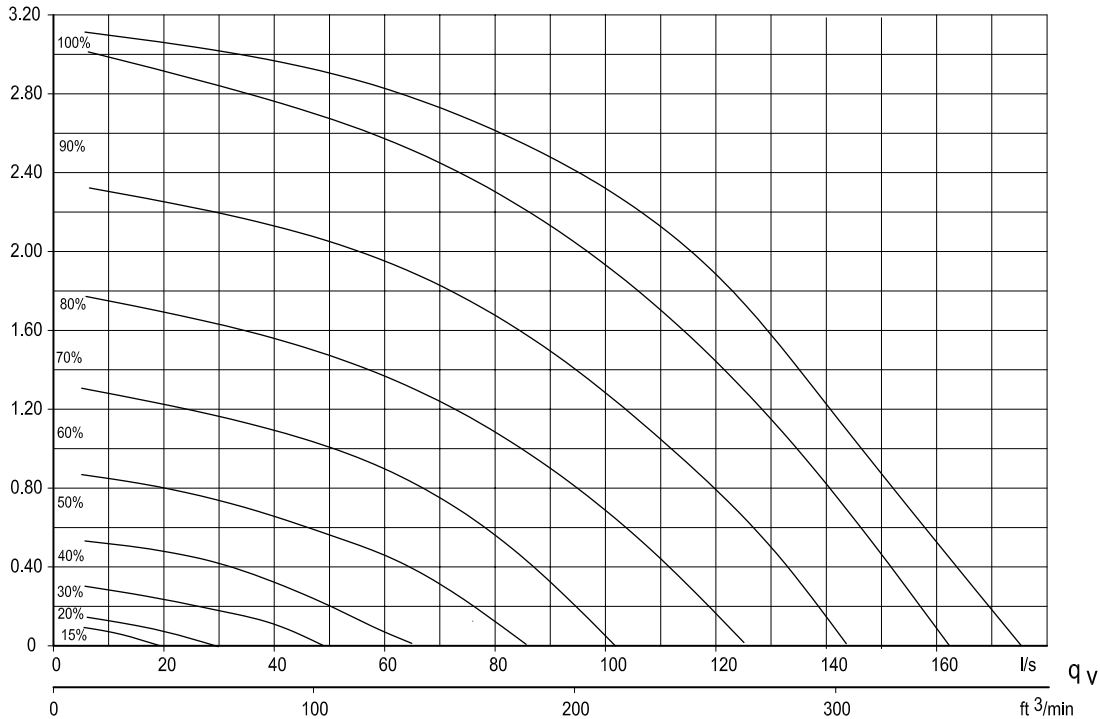

This can be done using the air specifications of the ComfoAir above.



The default settings of the ComfoAir nL are:

Position ABSENT	15%
Position LOW	35%
Position MEDIUM	50%
Position HIGH	70%

The default settings of the ComfoAir HL are:

Position ABSENT	15%
Position LOW	40%
Position MEDIUM	70%
Position HIGH	90%

Follow this procedure to programme the ComfoAir (after installation):

1. Set the ComfoAir in programming mode.
 - ComfoSense panel:
 - a. Press OK. The display shows SHIFT for 8 seconds.
 - b. Press MENU before the SHIFT text disappears. The display now shows COMF.
 - c. Press  or  to select INIT.
 - d. Press OK. The display flashes the text INIT ON.
 - e. Confirm with OK. The display shows OK for 2 seconds.

The text INIT is visible in the main menu.



In programming mode, the bypass valve is always closed. After 30 minutes, the ComfoAir automatically terminates the programming mode.

2. Close all windows and outside doors.

3. Close all inside doors.

4. Check the presence of structural overflow provisions.



The structural overflow provisions must be at least 0,41 inch per gallon/second (12cm² per l/s).

5. Check if both fans function in the three speed settings.
6. Switch the ComfoAir to high speed.
7. Install all valves and set the valves according to the settings given or as set in the reference house.

If no data are known:



- Install the valves and **open** them as far as possible.
- Measure the air volumes; starting with the intake air and then the exhaust air.
- If the measured air volumes deviate from the nominal air volumes by more than +/-10%, and the majority of the deviations is positive, **ensure** that all deviations are positive. If the majority of all deviations is negative, **ensure** that all deviations are negative. **Ensure** that one supply valve and one exhaust continue to be fully open.

8. Change the fan settings in P menus P30 to P37 of the digital operating device.
 - Select the lowest possible setting in order to conserve energy.
 - Ensure that the ratios between low, medium and high remain equal.



Use the chart of the ComfoAir's air specifications to set the fans.

9. In the event that the currently set air volumes still

- deviate too much: Adjust the valves.
10. Check the entire installation again, after all valves have been set.
 11. Switch the ComfoAir (back) to ventilation position 2.
 - ComfoSense panel:
 - a. Press OK. The display shows SHIFT for 8 seconds.
 - b. Press MENU before the SHIFT text disappears. The display now shows COMF.
 - c. Press  or  to select INIT.
 - d. Press OK. The display flashes the text INIT OFF.
 - e. Confirm with OK. The display shows OK for 2 seconds.

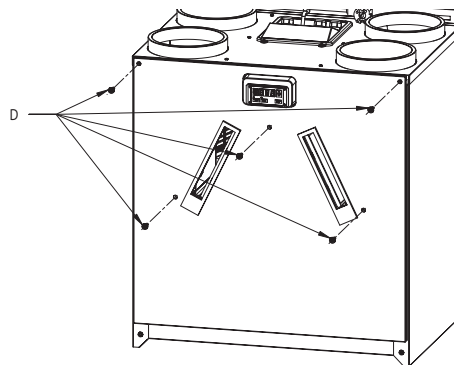

2.9 Maintenance by the installer

The following maintenance must be carry out by the installer:

- Inspecting and (if necessary) cleaning the heat exchanger;
 - Inspecting and (if necessary) cleaning the fans.
- A concise explanation of these maintenance activities is given in the paragraphs below.

 **Check the condensation drain once every 2 years.**

 **Failure to carry out (periodic) maintenance on the ComfoAir ultimately compromises the performance of the ventilation system.**

2.9.1 Inspecting and cleaning the heat exchanger

 **Check the heat exchanger once every 2 years.**

1. Disconnect the power (A) from the ComfoAir.
2. Remove the handles (B) from the ComfoAir;
3. Remove the filters from the ComfoAir.
4. Release the front panel by unscrewing the screws (C).
5. Slide the front panel upwards and **remove** the front panel from the ComfoAir.

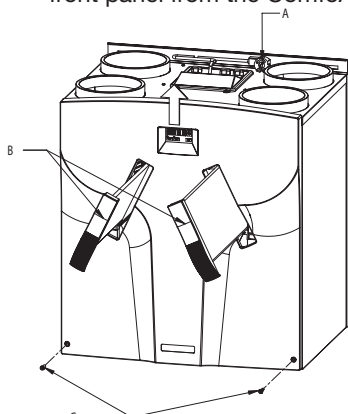

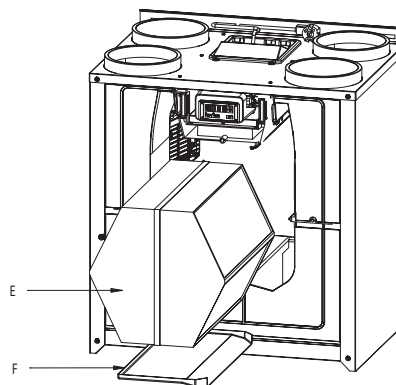

6. Release the cover panel by unscrewing the screws (D).
7. Remove the cover panel.

 **When reassembling the front cover, the lower section must first be inserted behind the raised edge to ensure a good seal.**



8. Pull the strap (E) to remove the heat exchanger and the leakage tray (F).
9. Remove the heat exchanger from the leakage tray (F).

 **Install the leakage tray correctly underneath the heat exchanger. The slanting side of the leakage tray must be on the side of the condensation drain.**

 **During assembly of the heat exchanger, check the position of the four rubber seals.**

10. Inspecting and if necessary clean the heat exchanger.
 - Use a soft brush to clean the lamellae.
 - Use a vacuum cleaner or air gun (no high pressure) to remove dirt and dust.

 **Always clean against the direction of the air-flow. This prevent dirt from getting stuck in the heat exchanger.**

- a. Submerge the heat exchanger several times in hot water (max. 40 °C).
- b. Rinse the heat exchanger with clean hot tap water (max. 40 °C).
- c. Clasp the heat exchanger between both hands (on the coloured side surfaces) and shake the water from the heat exchanger.

 **Do not use aggressive cleaning agents or solvents.**

👉 If the fans also need maintenance do not re-install the heat exchanger yet.

11. If no more maintenance is necessary install all parts in reverse order, reconnect the power and carry out the self-test in accordance with menu P76.

⚠️ Fasten the screws to a maximum of 1.2 ft.lbf (1.5Nm). This is roughly equal to setting 2 of an average battery-powered drill.

2.9.2 Inspecting and cleaning the fans

👉 Check the fans once every 2 years.

1. Remove the heat exchanger as instructed in the maintenance chapter of the heat exchanger.
2. Remove the screw from the electronics carriage.
3. Pull the electronics carriage carefully forwards.
4. Release the connectors (J) and the earth wire on the control circuit board panel and fully remove the cables including the two grommets (K).
5. Remove the entire scroll casing (L) by pressing the click fasteners (M).
6. Remove the inflow nozzle (N) by pressing the click fasteners surrounding the scroll casing.
7. Inspecting and if necessary clean the fans (O).
 - Use a soft brush to clean the fan impellers.
 - Use a vacuum cleaner to remove dust.

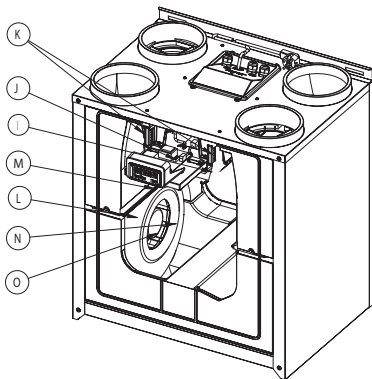

⚠️ Do not damage the fan impellers or temperature sensor.

8. If no more maintenance is necessary install all parts in reverse order, reconnect the power and carry out the self-test in accordance with menu P76.

⚠️ Fasten the screws to a maximum of 1.5 Nm. This is roughly equal to setting 2 of an average battery-powered drill.

2.10 Malfunctions

Malfunctions in the ComfoAir are reported as follows:

- The malfunction alert appears on the ComfoSense panel.

Malfunction alerts may not appear on the digital operating device in all cases, even though there is a malfunction (or problem). A concise explanation of both types of malfunction (or problem) is given in the paragraphs below.

2.10.1 Malfunction alerts on the digital operating device

In the event of a malfunction, the corresponding malfunction code will be displayed on the digital operating device of the ComfoAir.

Below is a list of the malfunction alerts on the digital operating device.

In the chapter about trouble shooting is explained how to solve these malfunctions

Code	Description
A0	n/a
A1	NTC sensor T1 is defective. (= outside air temperature)
A2	NTC sensor T2 is defective. (= supply air temperature)
A3	NTC sensor T3 is defective. (=return air temperature)
A4	NTC sensor T4 is defective. (= exhaust air temperature)
A5	Malfunction in the bypass motor.
A6	n/a
A10	n/a
A11	NTC sensor Tah is defective. (= afterheater temperature)
E1	Exhaust fan not rotating.
E2	Supply fan not rotating.
E4	ComfoAir has been switched off by external contact.
EA1	Enthalpy sensor measures excessive Relative Humidity (RH) values.
EA2	No communication between the enthalpy sensor and the ComfoAir.
COMM ERROR	No communication between the ComfoSense panel and the ComfoAir.
FLTR	Internal Filter is dirty.
FLTR EXT	External Filter is dirty.

2.10.2 What to do in the event of a malfunction / Trouble shooting

Below are a number of trouble-shooting tips for the malfunction alerts described previously which can appear on the digital operating device in the event of a malfunction.

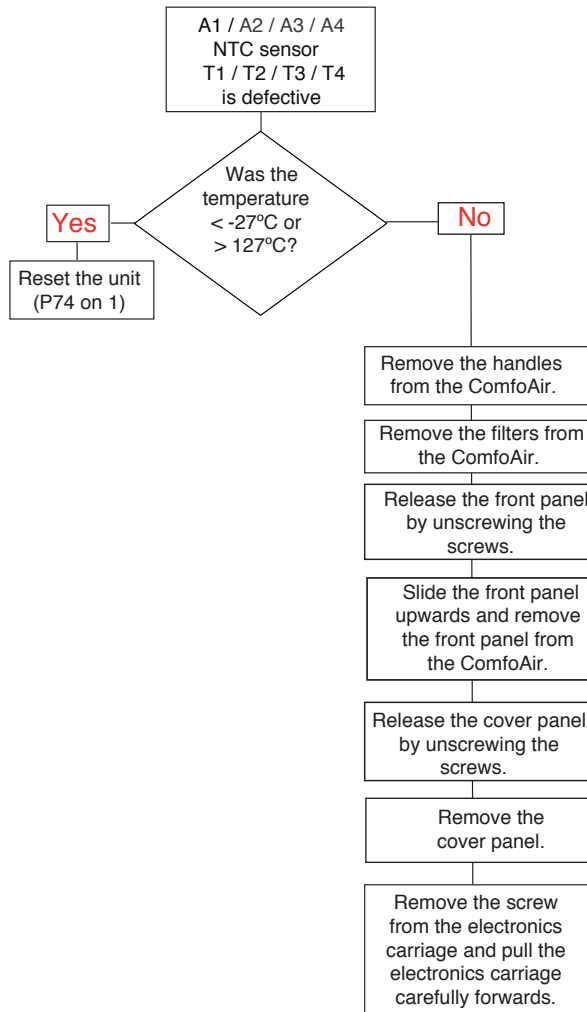

Resistance table for
(NTC) temperature sensors:

Temperature [°C]	Resistance [KΩ]		
	MIN.	MID.	MAX.
10	19,570	19,904	20,242
15	15,485	15,712	15,941
18	13,502	13,681	13,861
19	12,906	13,071	13,237
20	12,339	12,491	12,644
21	11,801	11,941	12,082
22	11,291	11,420	11,550
25	9,900	10,000	10,100
30	7,959	8,057	8,155



Risk of electrocution.

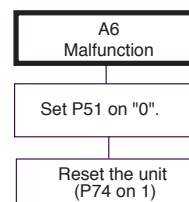
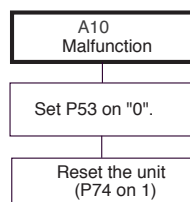
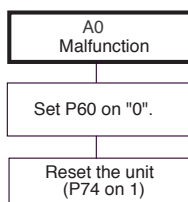
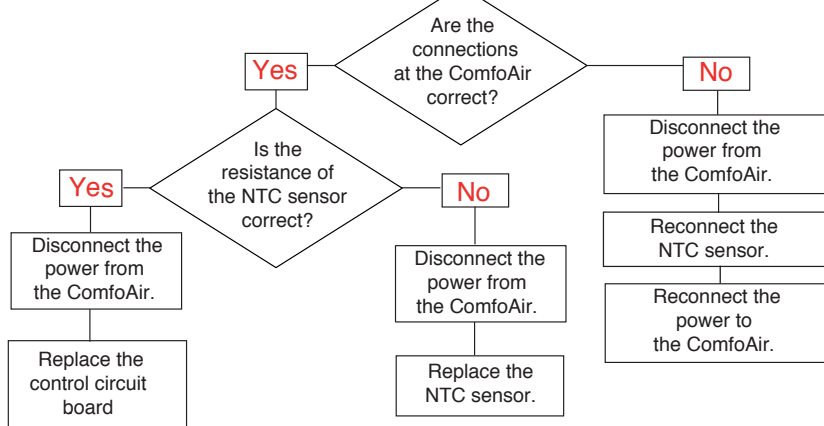

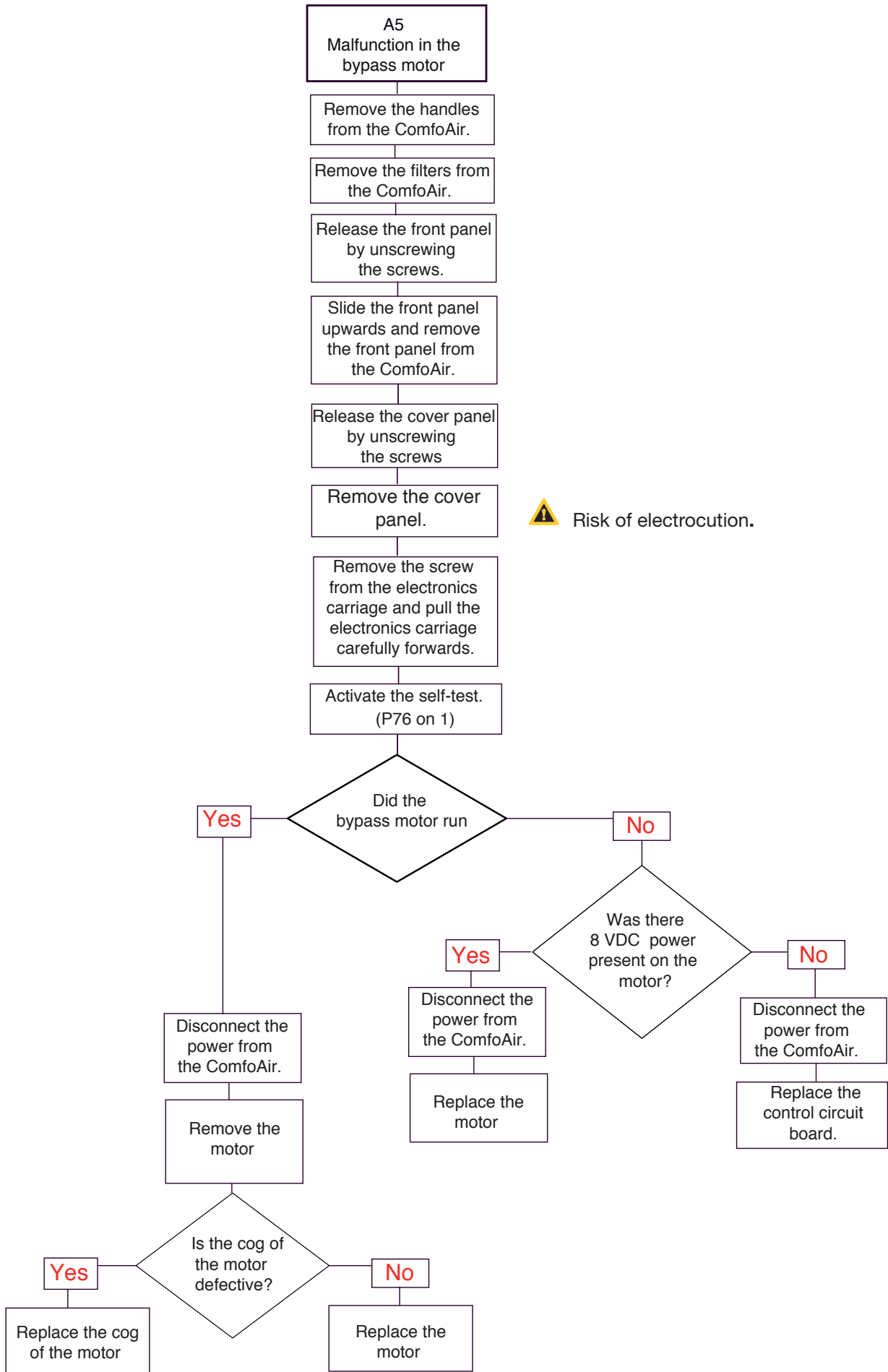

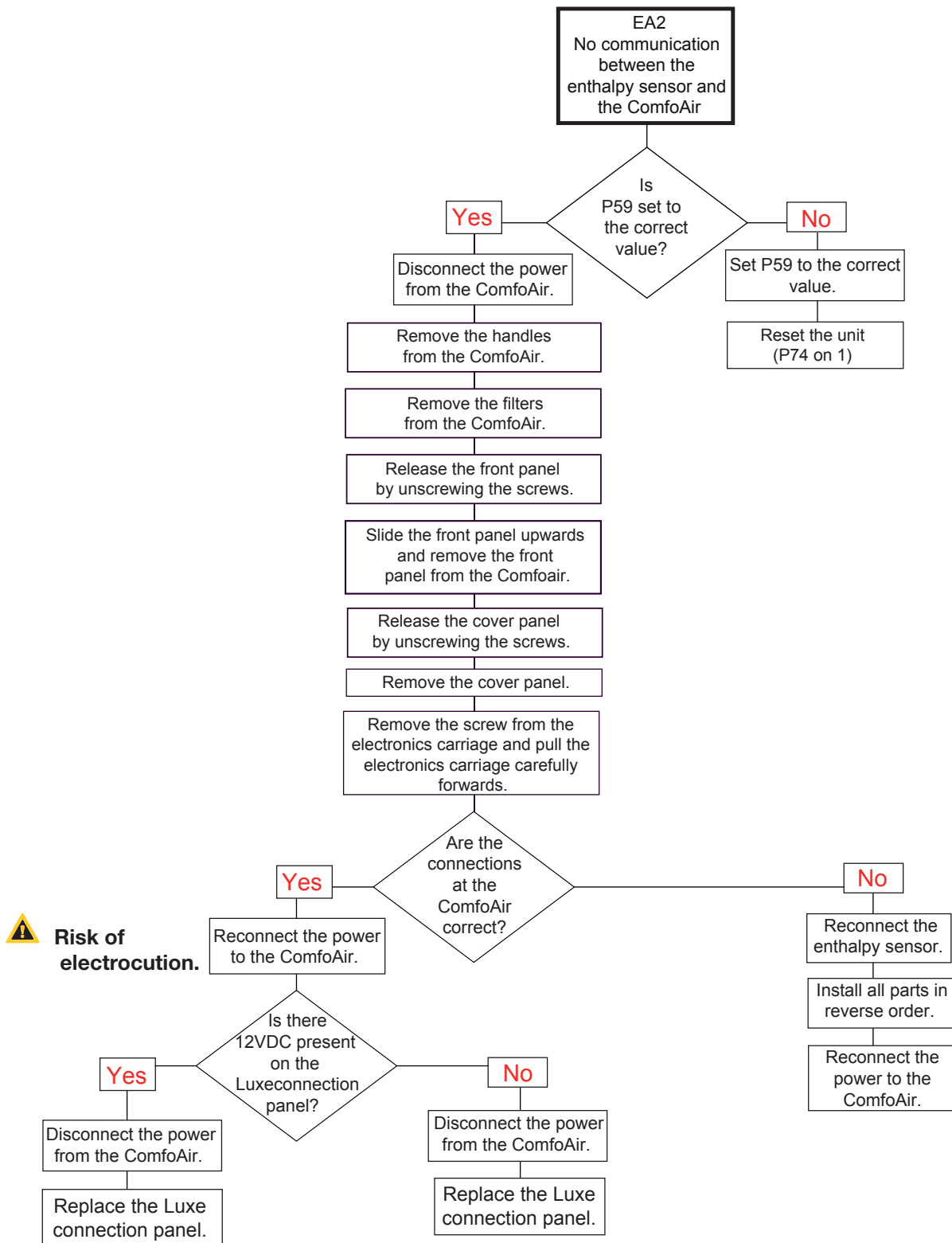

E1 / E2
Supply fan / Exhaust fan not rotating

Remove the handles from the ComfoAir.

Remove the filters from the ComfoAir.

Release the front panel by unscrewing the screws.

Slide the front panel upwards and remove the front panel from the ComfoAir.

Release the cover panel by unscrewing the screws.

Remove the cover panel.

Remove the screw from the electronics carriage and pull the electronics carriage carefully forwards.



Risk of electrocution.

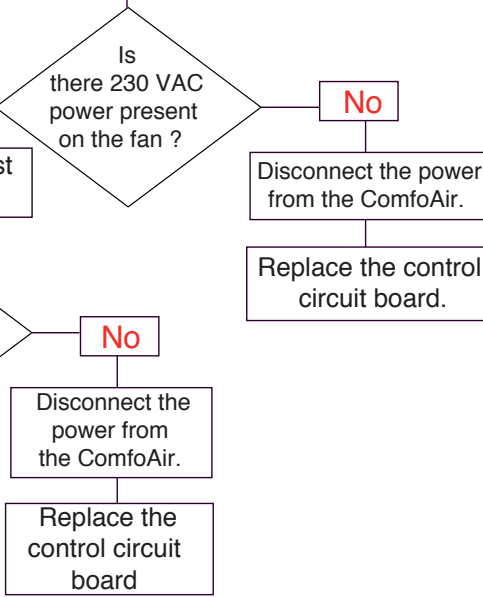

E4
ComfoAir has been switched off by external contact



Risk of electrocution.

Cause depends on what equipment is interfaced with the ComfoAir. Check the relevant device

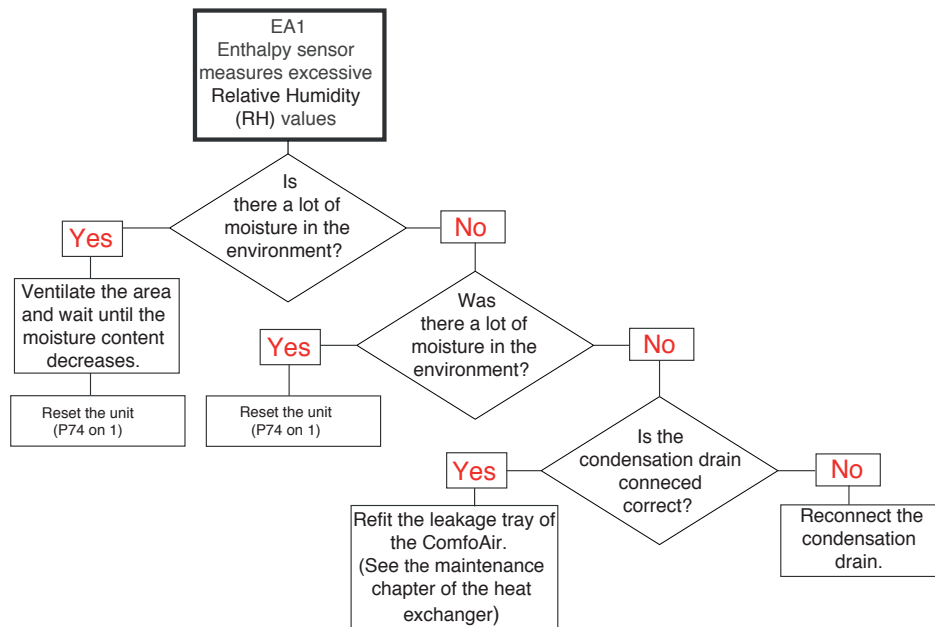

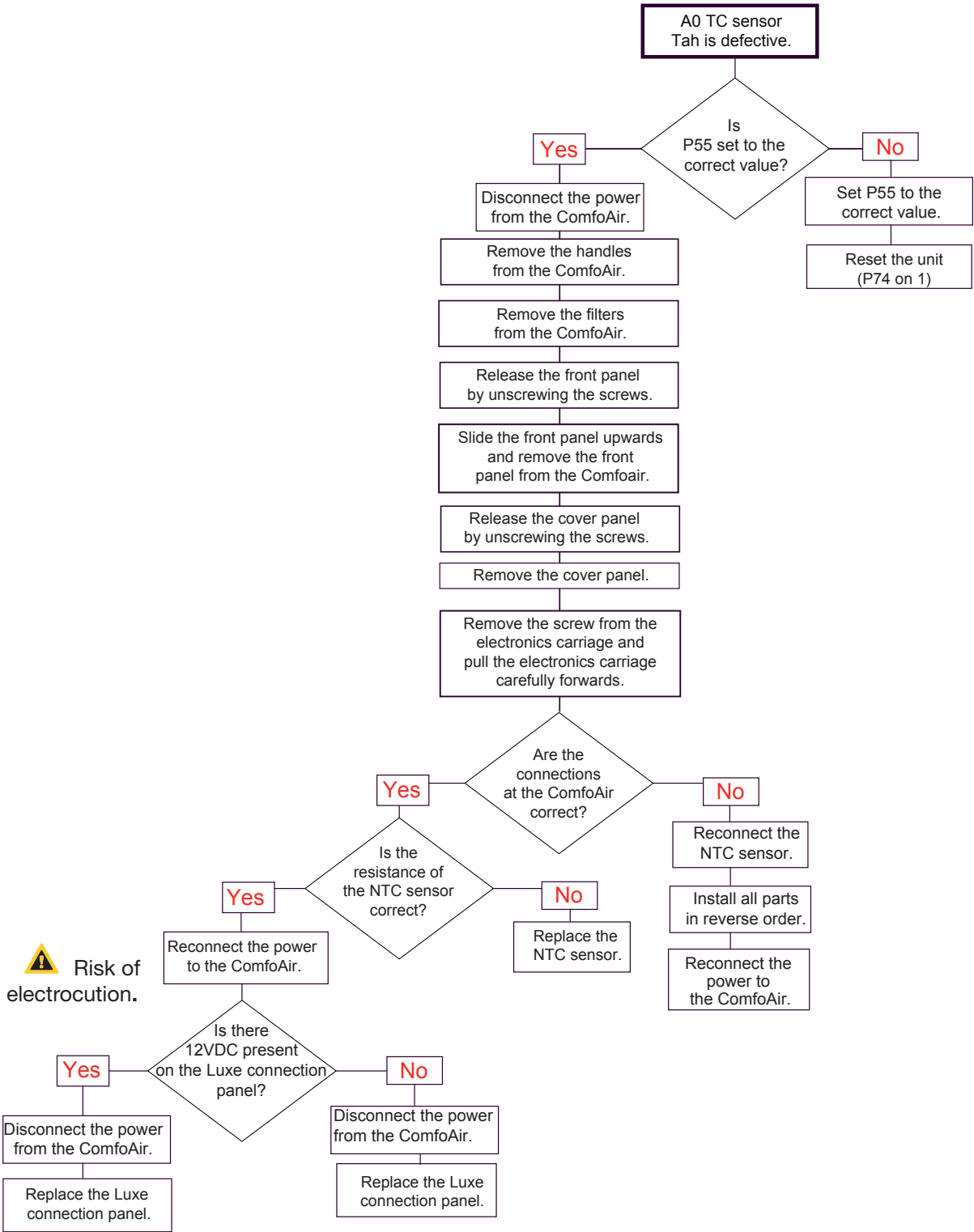

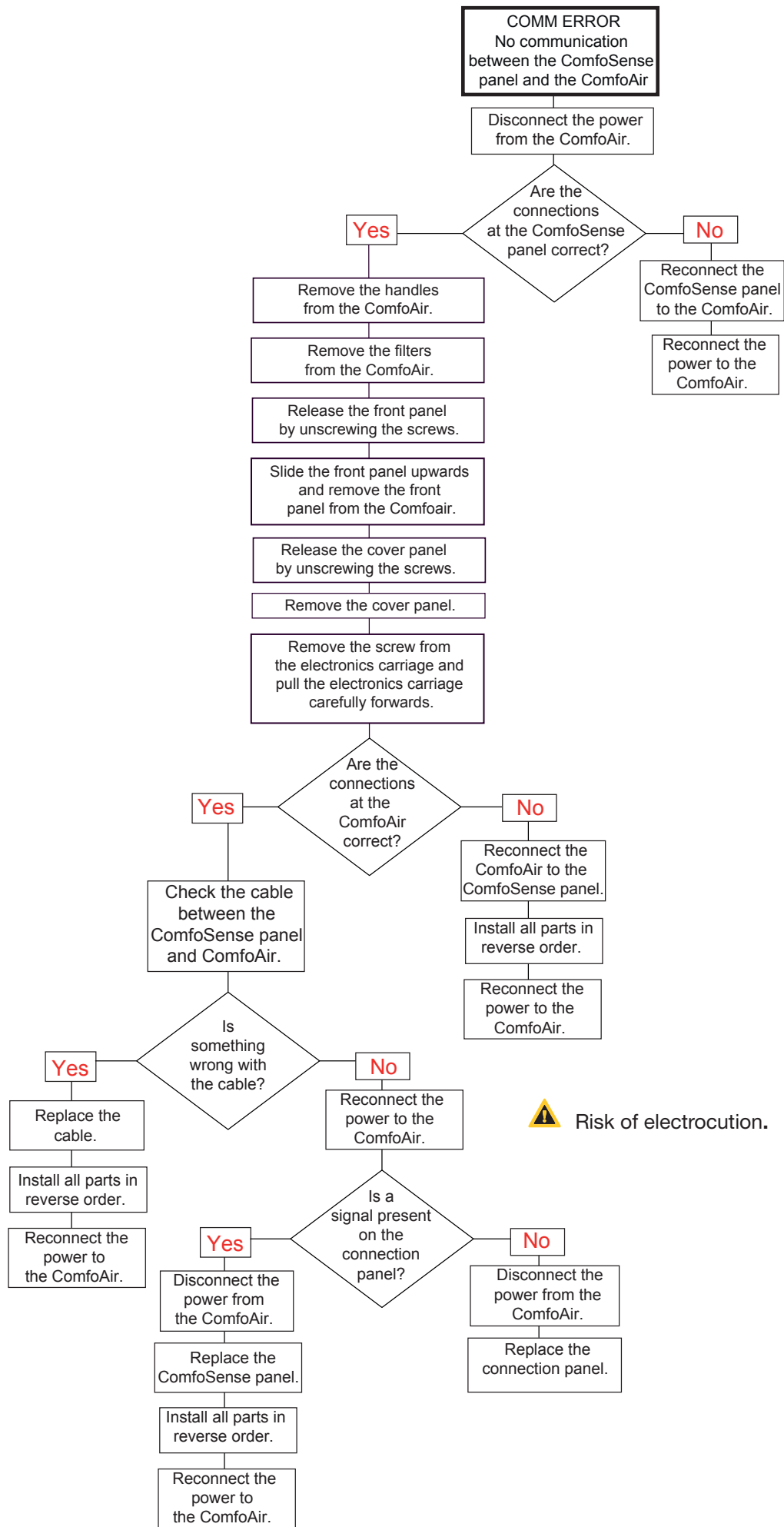

FLTR
Internal Filter is dirty

Press OK on the ComfoSense panel 2x to reset the FLTR warning.

Disconnect the power from the ComfoAir.

Remove the handles from the ComfoAir.

Remove the dirty filters from the ComfoAir.

Slide the clean (new) filters back into the ComfoAir.
Cleaning: Vacuum the filters with a vacuum cleaner.

Refit the handles to the ComfoAir.

Reconnect the power to the ComfoAir.

FLTR EXT
External Filter is dirty

Clean or replace the External filter according to its own instruction.

2.10.3 Malfunctions (or problems) without alerts

An overview of the malfunctions (or problems) without notifications is given below.

Problem/Malfunction	Indication	Check / action
System switched off	Power supply on	The control circuit board is defective and must be replaced.
	No power supply	Mains power is off.
High intake temperature in summer	Bypass remains closed	Reduce the comfort temperature.
	ComfoAir is still in Winter mode: Bypass remains closed	Checking the Mode of the ComfoAir is possible with special read-out software. ■ Wait until ComfoAir switches to Summer mode.
Low intake temperature in winter	Bypass stays open	Increase the comfort temperature.
Little or no air supply; shower remains damp	Filters blocked	Replace the filters.
	Valves blocked	Clean the valves.
	Exchanger clogged by dirt.	Clean the exchanger.
	Exchanger frozen	Defrost the exchanger.
	Fan dirty	Clean the fan.
	Ventilation ducts blocked	Clean the ventilation ducts.
	ComfoAir is in frost-protection operation	Wait until the weather warms up.
Too noisy	Fan bearings defective	Replace the fan (bearings).
	Fan settings to high	Change the fan (settings).
	Slurping noise ■ Siphon is empty ■ Siphon does not seal properly	Reconnect the siphon.
	Whistling noise ■ An air gap somewhere	Seal the air gap.
	Airflow noise ■ Valves do not close onto duct. ■ Valves not open far enough	Reinstall the valves. Reset the valves.
	Condensation leak	Condensation drain clogged
	Condensation from exhaust duct does not run into leakage tray	Check whether the connections are correct.

2.11 Service parts

The following table contains an overview of the spare parts available for the ComfoAir.

Number	Part	Art.nr.
1	Fan (left/right)	400200015
2	Servo motor & cable (for the bypass and the pre-heater)	400300024
3	Temperature sensor T1 / T3 (in top of unit; near the electronic carriage)	400300025
4	Temperature sensor T2 / T4 (in scroll casing of both fans)	400300026
6	Filter (2x)	400100085
8	Connector panel in ComfoAir;	400300053
10	ComfoAir control PCB	400300053
12	Enthalpy heat exchanger	400400014

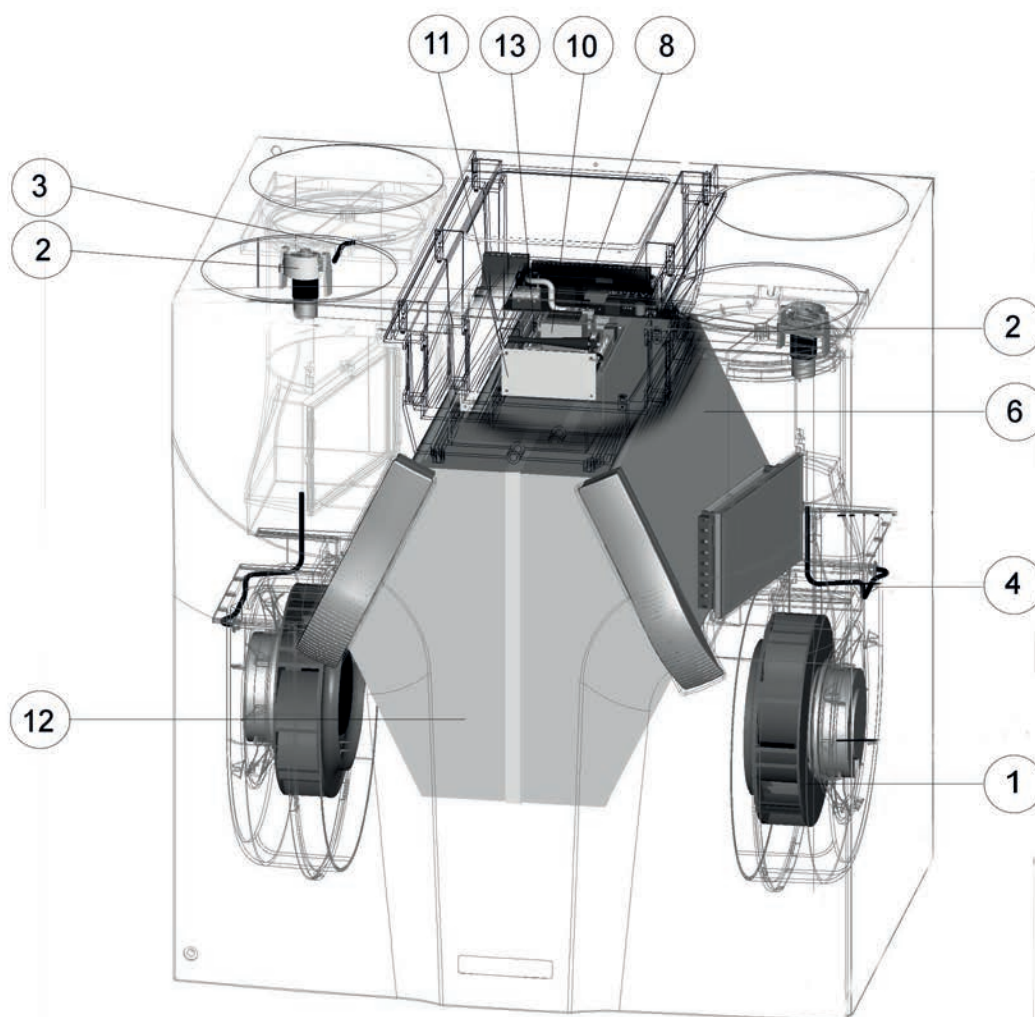

2.12 Wiring diagram: ComfoAir 550 Luxe – LEFT-HAND version

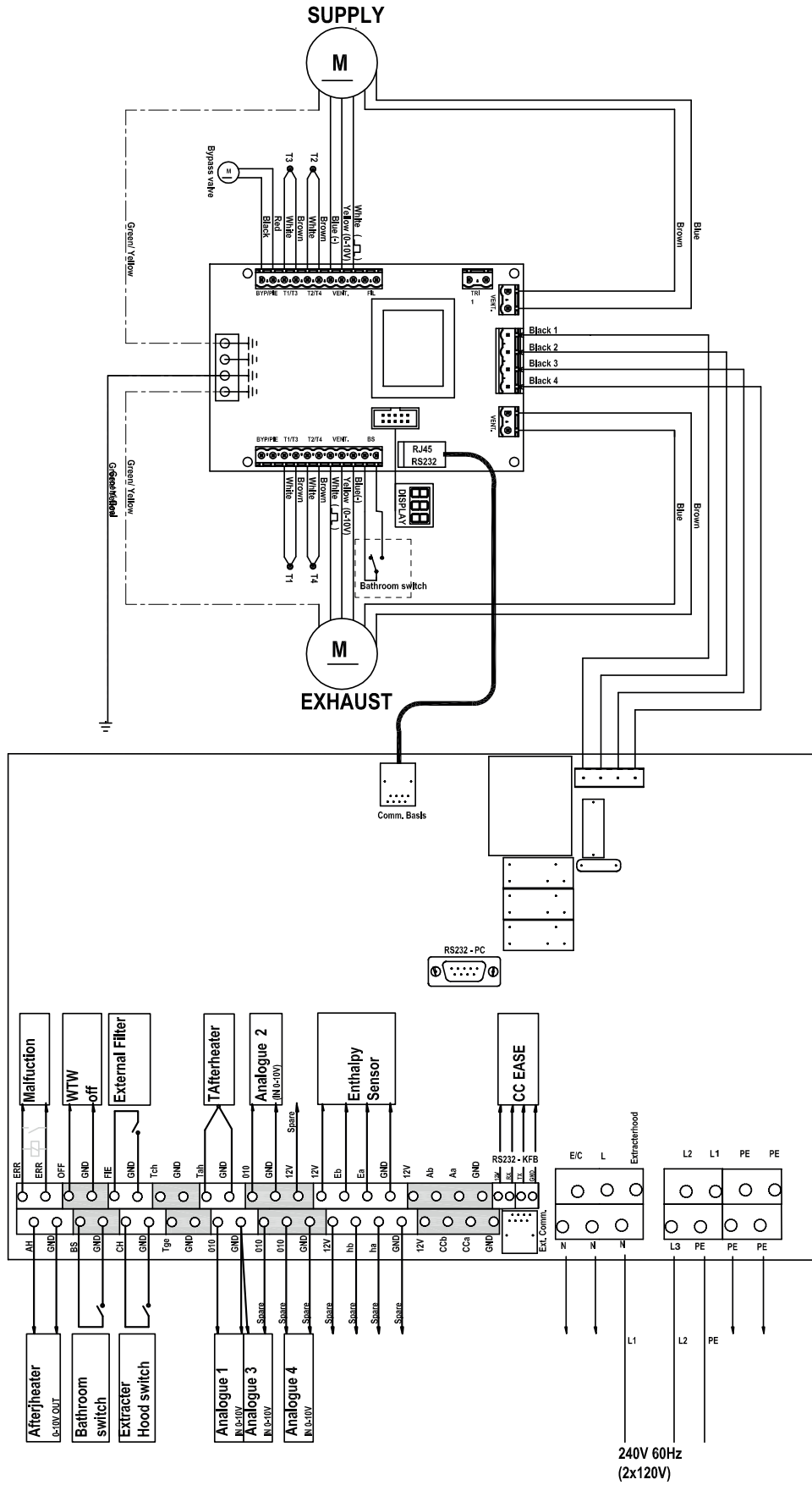

2.13 Wiring diagram: ComfoAir 550 Luxe – RIGHT-HAND version

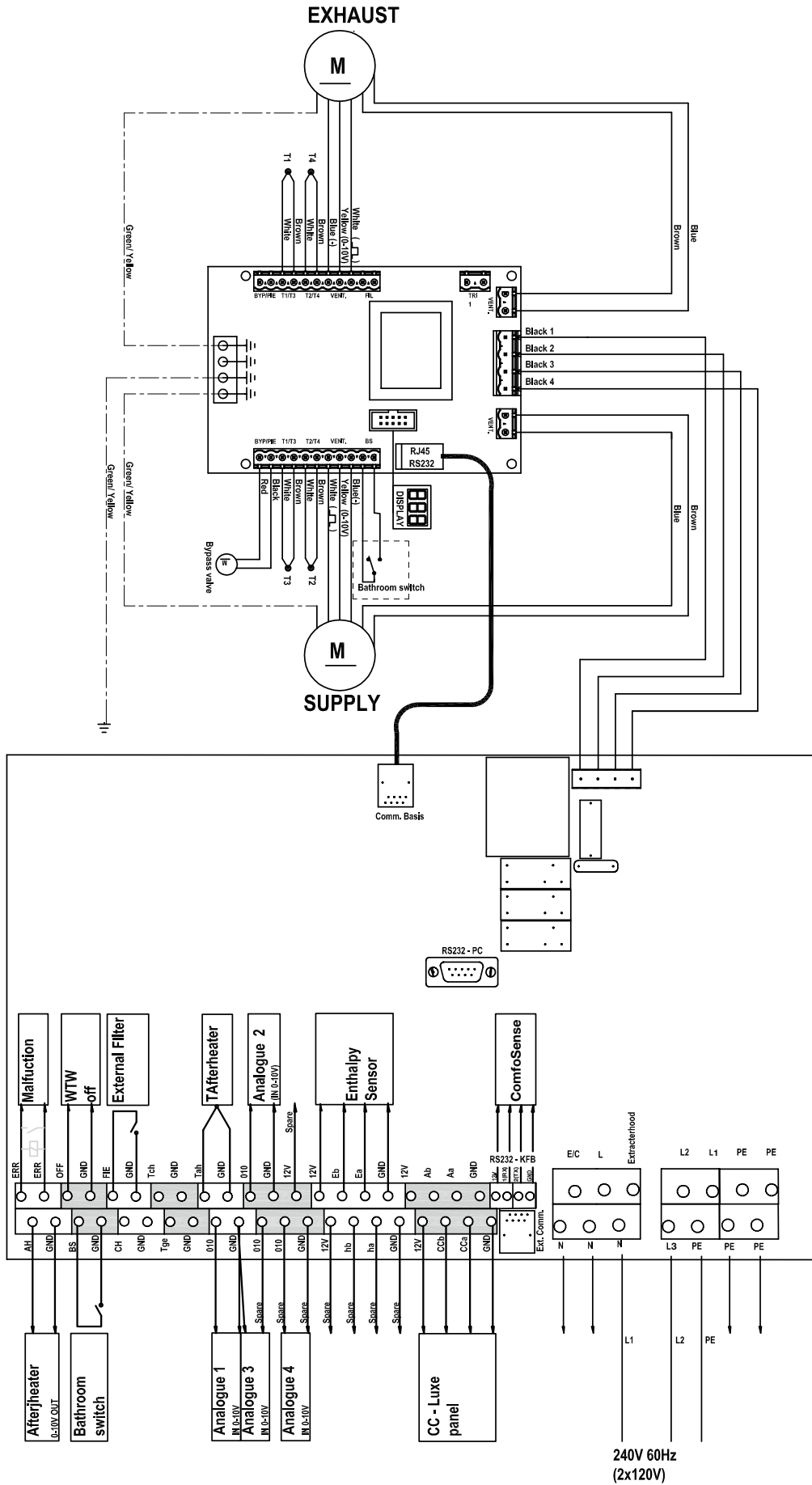

2.14 UL Listing Declaration

This product is Listed by UL. Representative samples of this product have been evaluated by UL and meet applicable USA and Canadian safety standards.

Product: ComfoAir 550 USA Luxe

UL file number: E345822



2.15 Temperature conversion table

°C	°F	°C	°F
5	41.0	23	73.4
6	42.8	24	75.2
7	44.6	25	77.0
8	46.4	26	78.8
9	48.2	27	80.6
10	50.0	28	82.4
11	51.8	29	84.2
12	53.6	30	86.0
13	55.4	31	87.8
14	57.2	32	89.6
15	59.0	33	91.4
16	60.8	34	93.2
17	62.6	35	95.0
18	64.4	36	96.8
19	66.2	37	98.6
20	68.0	38	100.4
21	69.8	39	102.2
22	71.6	40	104.0

$$^{\circ}\text{F} = ^{\circ}\text{C} \times 1.8 + 32$$





