

Application

The Zehnder ComfoFond-L eco brine geothermal heat exchanger has been developed for use in conjunction with the ComfoAir 350 Luxe and ComfoAir 550 Luxe comfort ventilation units. It combines the highest comfort with very high efficiency and a compact installation. In winter, when the outdoor temperatures are low, it heats the outside air and keeps it free from frost. This ensures optimum operation of the ComfoAir ventilation unit, even at outdoor temperatures below the freezing point. In summer, the ComfoFond-L eco lowers the temperature of the outside air, and helps to support a conventional air-conditioning system. During this time, the ground loop or the ground collector is recharged.

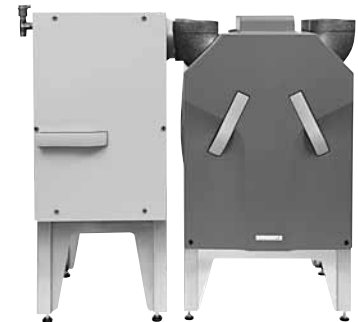

Filter

As standard, the ComfoFond-L eco is equipped with a filter insert corresponding to that of the connected ventilation unit. A class G4 coarse dust filter is supplied. The universal filter makes it possible to install the outside air filter of the ventilation unit in the ComfoFond-L eco, as well as having a G4 prefilter in the ComfoFond-L eco and installing a pollen filter into the ventilation unit. This means the service lives of the individual filters are extended, and the pressure loss is minimised over a long time.

Installation

The ComfoFond-L eco is characterised by its compact installation directly adjacent to the ventilation unit. All connections and connecting components are supplied with the ComfoFond-L eco. The connections for the outside air and the brine lines are arranged on the side. In a comfort ventilation unit with the connections for the supply air and exhaust air on the left (e.g. ComfoAir 350 L Luxe or ComfoAir 550 L Luxe), the ComfoFond-L eco is installed on the right next to the ventilation unit. In comfort ventilation units with the supply and exhaust air connections on the right, installation is on the left correspondingly. Installation is possible on the wall and on the floor, in the latter case with the optionally available assembly bases. If the specific wall mass is 41 lb /sqft or less, the ComfoFond-L must be installed on the floor. The internal dry siphon of the ComfoFond-L must be connected to the drainage system via a vacant outlet (e.g. funnel siphon). If the ComfoAir ventilation unit is connected via the Zehnder dry siphon (Ref. No. 93 62) then it is permitted to have a shared condensation pipe (union in the flow direction after the particular dry siphon).

Operation

The ComfoFond-L eco is controlled via the electronic control unit of the connected ventilation unit. This involves setting a lower and an upper switch-on point, which control the functions of preheating and temperature control.

Servicing

The only servicing that the user needs to perform on the ComfoFond-L eco is to change the filters every six months, and to check the brine pressure. A specialist company should carry out a service once a year. This should involve cleaning the heat exchanger and the surfaces that come into contact with the air, checking for leaks in the hydraulic components and checking the function of the complete system. Please see the manual for additional servicing tasks.

Benefits

- Preheating the outside air in winter using geothermal energy
- Controlling the temperature of the outside air in summer and in winter for a comfortable indoor climate
- Compact, quick installation directly adjacent to the ventilation unit
- Using geothermal energy with low electricity consumption
- Brine pump with energy efficiency A rating
- Exchange of air in spite of low outside temperatures

Article numbers

L = in conjunction with ComfoAir 350/550 L Luxe

R = in conjunction with ComfoAir 350/550 R Luxe

Description	Article Number	Reference Number
ComfoFond-L eco 350 L	471 310 017	9403
ComfoFond-L eco 350 R	471 310 012	9406
ComfoFond-L eco 550 L	471 310 027	9404
ComfoFond-L eco 550 R	471 310 022	9407

Accessories		
ComfoFond-L eco 350 Stand	642 300 161	
ComfoFond-L eco 550 Stand	642 300 166	

Description

Zehnder ComfoFond-L eco brine geothermal heat exchanger suitable for ComfoAir 350/550 ventilation unit.

In winter, the ComfoFond-L eco preheats the outside air before it enters the ventilation unit; in summer it cools and dehumidifies the outside air. It is used to augment the ComfoAir ventilation unit and can be installed compactly directly adjacent to the ventilation unit. All necessary hydraulic components are included, such as the circulation pump, expansion tank, filling and flushing system, pressure gauge and a safety valve. All components are pre-installed in the housing of the ComfoFond-L eco. The ground collector pipe/ground loop connection with wall duct as well as brine fill are not supplied. The upstream G4 filter protects the heat exchanger against impurities, meaning that it can replace the outside air filter in the ventilation unit. It can also be combined with a pollen filter in the ventilation unit. The brine geothermal heat exchanger is activated and controlled directly by the control unit Ease or Luxe of the ComfoAir 350/550.

Technical specifications

Housing dimensions without connections	
Height (inch.)	30.0"
Width (inch.)	18.7"
Depth (inch.)	21.7"
Outside air connection 350/550 (inch.)	7"
Condensate connection	1¼ " male thread with 1 ¼" adapter
Brine connection	¾" male thread

General specifications

Operating temperature	-7.6 °F to 113 °F
Supply voltage	220/230 V AC, 50/60 Hz, 1-phase
IP protection class	44
Minimum current consumption	0.06 A
Maximum current consumption	0.58 A
Minimum power consumption	5 W
Maximum power consumption	70 W
Operating pressure	21.7 PSI
Fluid volume	1.32 gallon (excl. ground collector content)
Weight	92.6 lb

Brine geothermal heat exchanger

Zehnder ComfoFond-L eco

ComfoFond-L eco 350 L

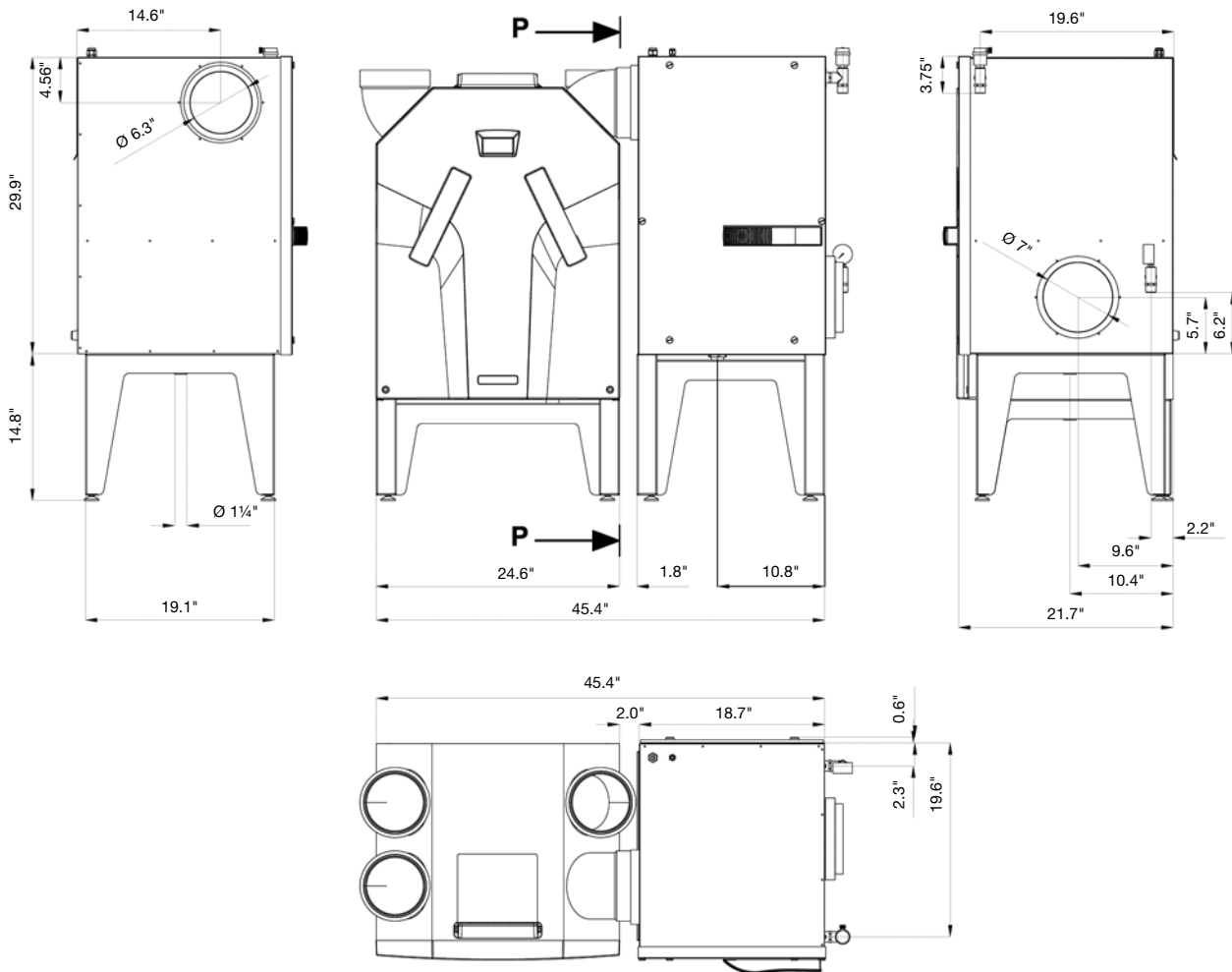

ComfoFond-L eco 350 R

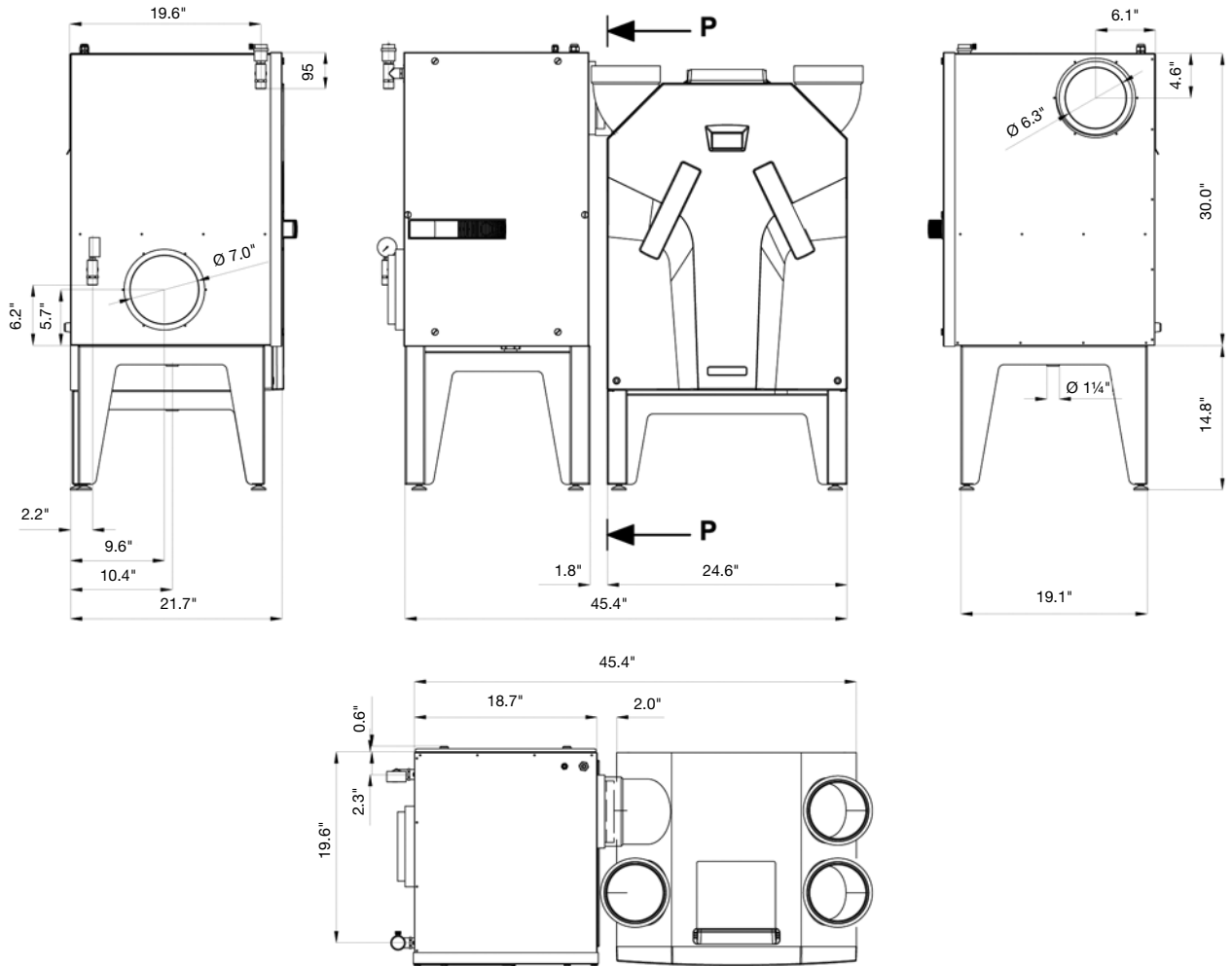

Brine geothermal heat exchanger

Zehnder ComfoFond-L eco

ComfoFond-L eco 550 L

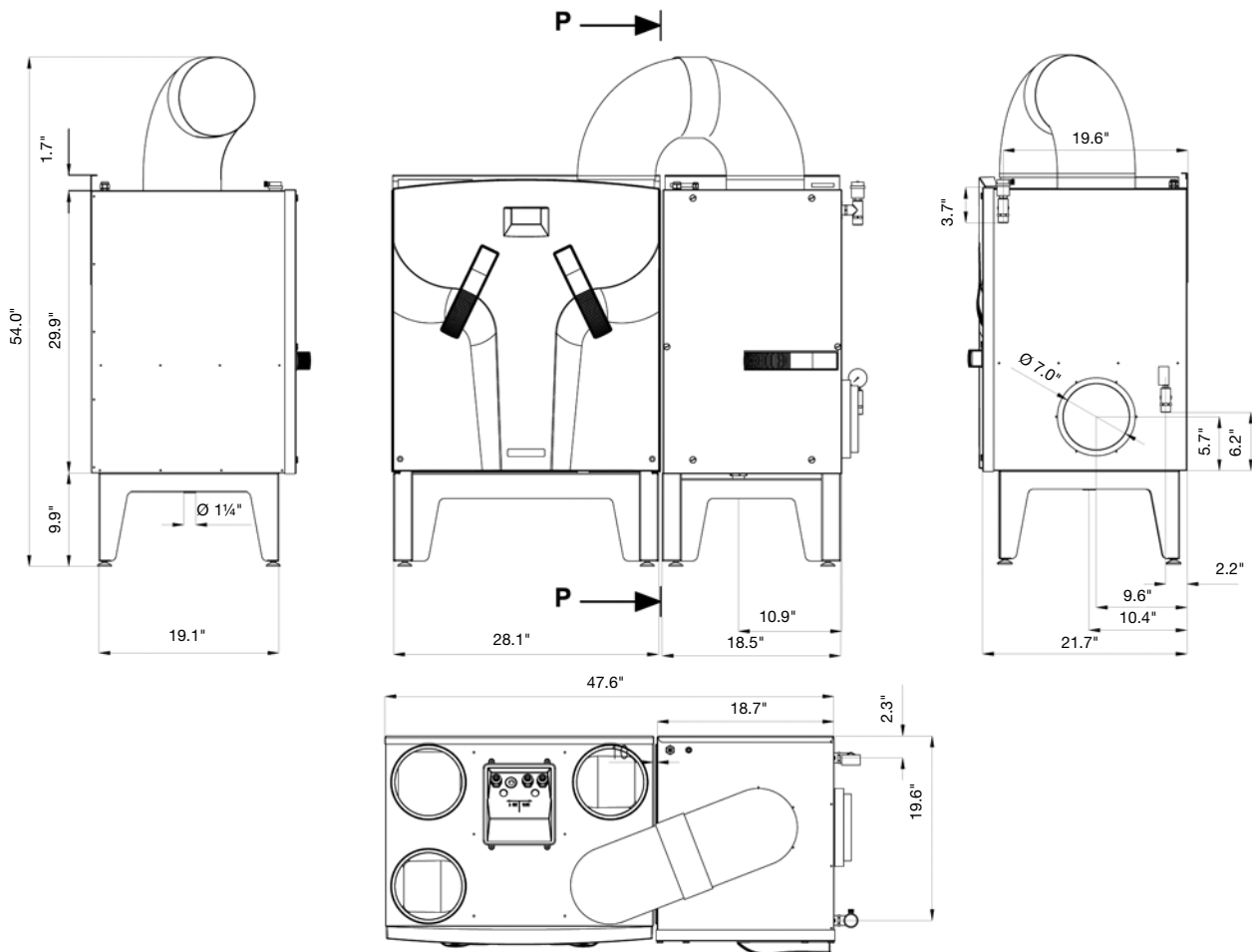

Brine geothermal heat exchanger

Zehnder ComfoFond-L eco

ComfoFond-L eco 550 R

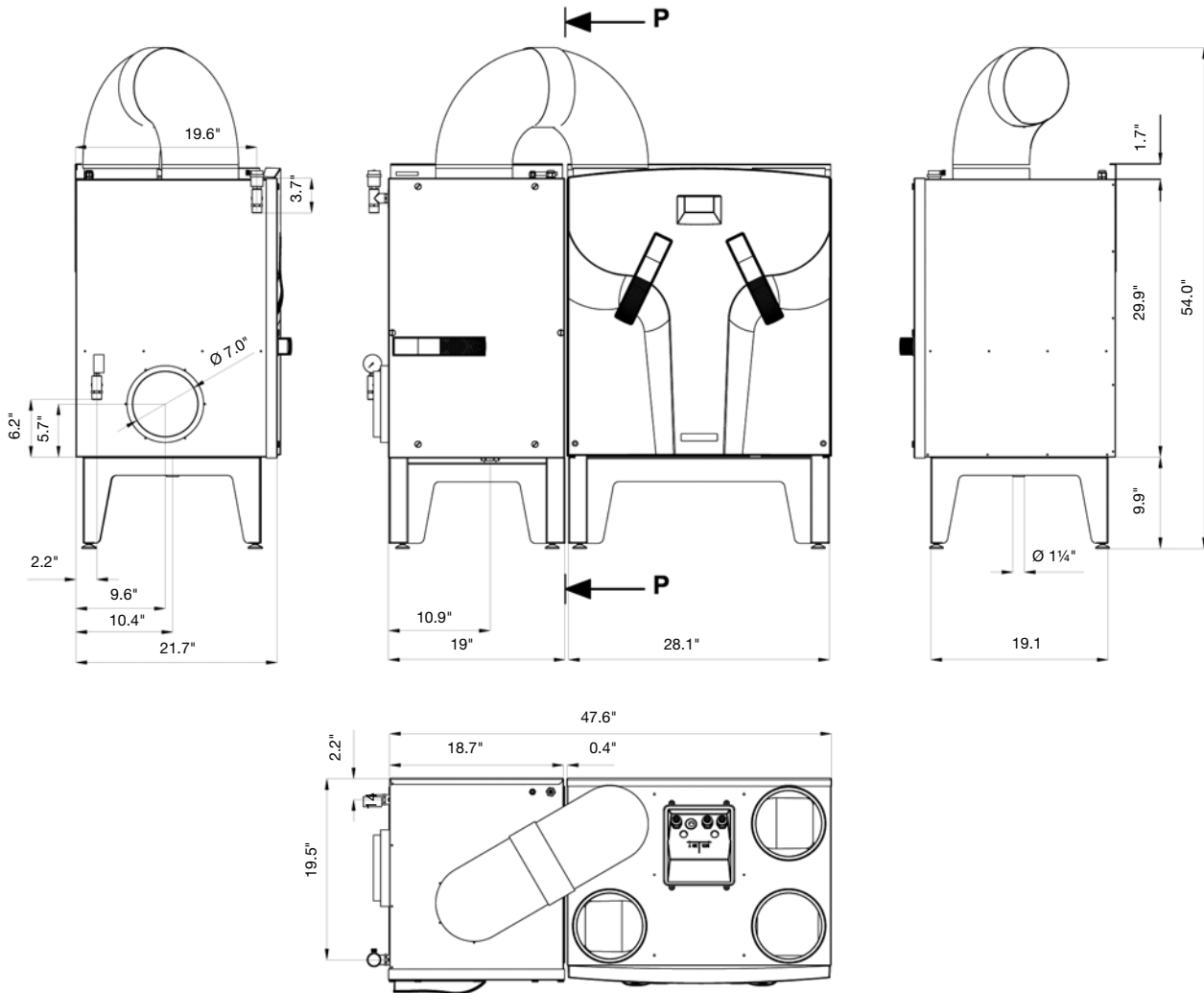

Terminal diagram

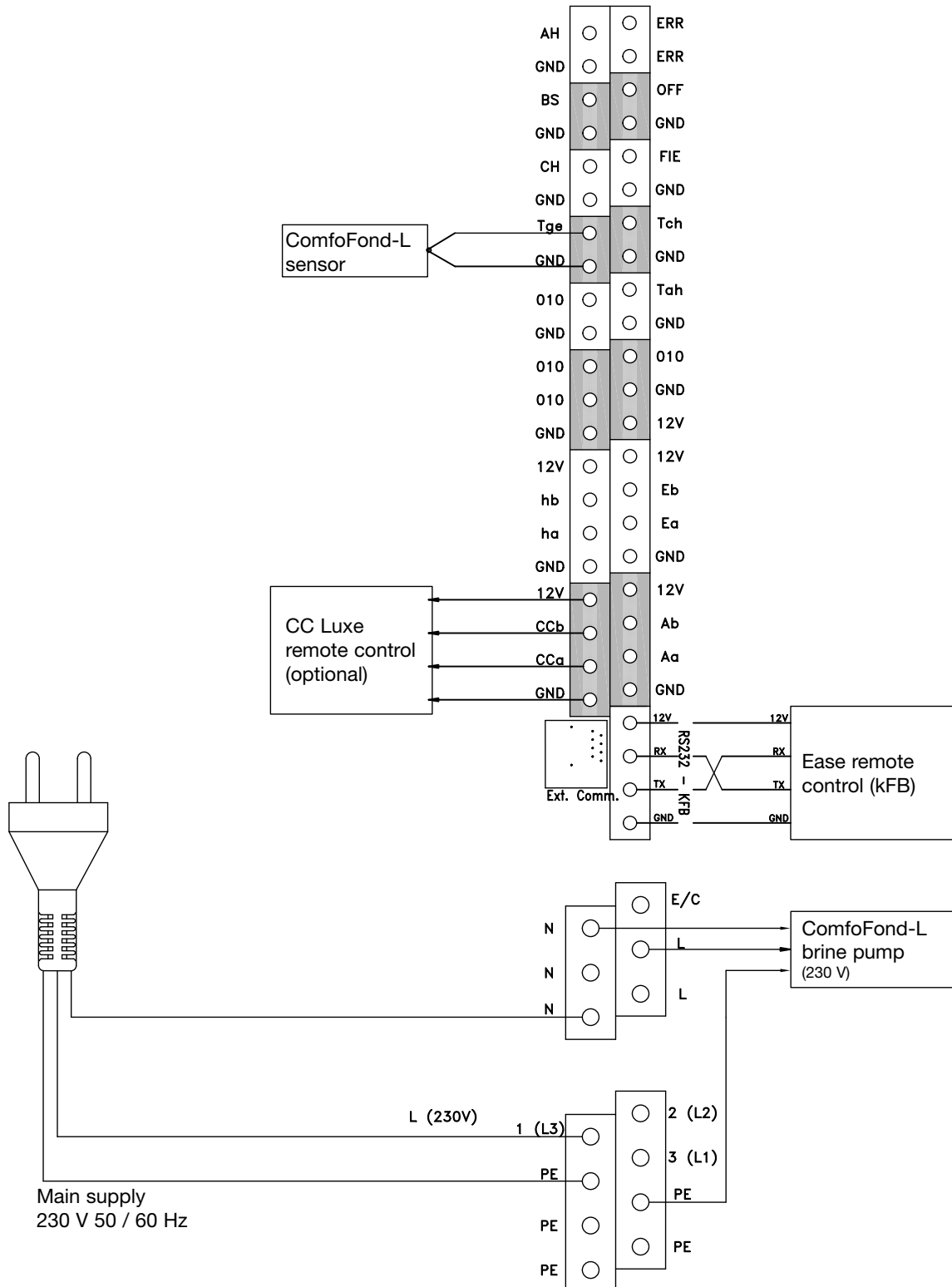

Equipment

- Brine pump energy efficiency A rated
- Safety valve: 43.5 PSI
- Automatic air vent
- Filling and flushing system
- Expansion vessel: 2 litres
- Pressure gauge: 0 to 145 PSI
- Internal dry siphon
- Connection pipe of pump and temperature sensor
- Connections 3/4" male thread for the brine pipes

Pressure losses and collector selection

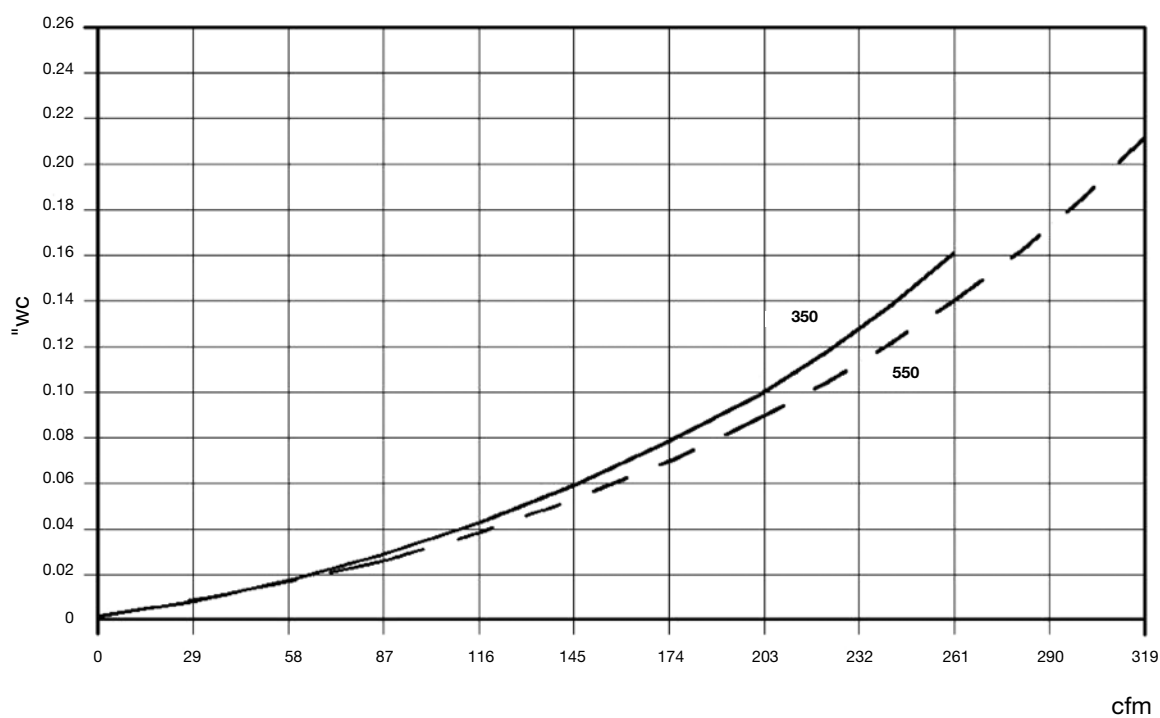

350 = ComfoFond-L eco 350 pressure loss

550 = ComfoFond-L eco 550 pressure loss

Pressure losses only take account of the pressure loss of the ComfoFond-L eco.
 A filter G4 is already included in the ventilation unit, and is installed in the ComfoFond-L eco.

Minimal requirements on the ground collector for pre-heating the outside air

ComfoFond-L eco 350

Ground type	Collector length [ft.]	Pump stage	Pipe dimension ["]	Brine frost protection content approx. [gallon]
Dry sand	360	3	1 ¼" / 1.6 x 0.15	23.08
Damp sand	230	3	1" / 1.3 x 0.11	13.2
Dry silt	295	3	1" / 1.3 x 0.11	15.09
Damp silt	230	3	1" / 1.3 x 0.11	10.6
Dry loam	265	3	1" / 1.3 x 0.11	13.2
Damp loam	230	4	¾" / 1.0 x 0.09	10.6
Dry clay	230	4	¾" / 1.0 x 0.09	10.6
Damp clay	200	4	¾" / 1.0 x 0.09	5.3

ComfoFond-L eco 550

Ground type	Collector length [ft.]	Pump stage	Pipe dimension ["]	Brine frost protection content approx. [gallon]
Dry sand	2 x 265	3	1 ¼" / 1.6 x 0.09	31.7
Damp sand	330	3	1 ¼" / 1.6 x 0.09	21.1
Dry silt	395	2	1 ¼" / 1.6 x 0.09	26.4
Damp silt	330	3	1" / 1.3 x 0.11	15.9
Dry loam	360	3	1 ¼" / 1.6 x 0.09	23.8
Damp loam	330	3	1" / 1.3 x 0.11	15.9
Dry clay	360	3	1" / 1.3 x 0.11	15.9
Damp clay	295	3	1" / 1.3 x 0.11	15.9

The recommended collector examples named here are recommended minimum requirements which may be increased depending on the location and the operating mode of the system. We recommend having the ground inspected by an expert. Also comply with the information in VDI 4640 regarding the use of shallow geothermal energy.

The data assumes a minimum outside temperature of -4°F and a laying depth of 4 ft. to maximum 6.6 ft. The named pump stages are reference values, and may vary depending on the configuration of the pipework in the building. The ground collector pipes are not allowed to be spaced less than 2 ft. apart in all directions and are also not allowed to be less than 3.3 ft. in any direction from pipes carrying water. It is not permitted for the collector field to be built over or sealed.

ZA-CSY--FLYERTS083, V0911, en_us, subject to changes